



AI & UBF Campus Mission

Two Paths — Restoring Time, Expanding Creativity

- Presenter: Dr. Joseph Cho
- WMC 2026 MSC IG
- 90-minute session

Voice Narration: AI-Cloned Voice of Joseph

Dr. Joseph Cho



1 |  B.S. & M.S., Computer Eng., Inha Univ.

2 |  21 years as an IT engineer at SK Group
(SK C&C, SK Innovation, SK Planet)

3 |  PhD in Data Science, Kookmin Univ.;
ML researcher at USC & Chapman

4 |  Now: UBF HQ IT Coordinator ·
founder, LC Lab, Inc. ·
Adjunct Professor, Grace Mission Univ. ·
author, Christians in the AI Age



Using IT and AI: UBF Mission Case Studies

- **KIMNET Conference** (Seattle, Nov 2025) — presented UBF AI ministry cases
- Inspired mission & church leaders beyond UBF
- Invited as Adjunct Professor, **Grace Mission University**
- Course: "Integrated AI Applications for Ministry"
- **AI & Sermon Seminar** for Korean pastors, S. California (3/10/2026)

Today's Discernment Framework



1 Thess 5:21 — test everything; hold fast to what is good

1 Cor 6:12 — all is lawful, but I will not be enslaved by anything

Neither fear nor uncritical adoption — but discernment

“Test everything; hold fast to what is good; abstain from every form of evil.”

— 1 Thessalonians 5:21-22 (ESV)

PART I · Awareness — What Are We Facing?

The Challenge of the AI Era

Ch 1 — The Essence of
Generative AI

Ch 2 — The Great Shift:
Jobs, Industry, Education

Ch 3 — The Limits and
Hidden Risks of AI

What is Generative AI?

Word Prediction · Language Model

A giant auto-complete: predicts the next word

G

Generative

P

Pretrained

T

Transformer

The quick brown fox jumps over the **lazy**

A probability model that predicts the next word.

How GPT Is Built: 3 Stages

1



2



3

Pre-training — trillions of words from the internet

Fine-tuning — domain specialization

RLHF — reinforcement learning from human feedback

⚠ Stage 3 is where sycophancy begins

Synthesis: AI Is Not True Intelligence

- Understand the **nature of the tool**

Imago Dei

Contrast Matrix

The Simulation



1. No true comprehension

No understanding of meaning, context, or self. Merely processes patterns.



2. No emotion or empathy

Simulates emotional responses without experience. Cannot feel or care.

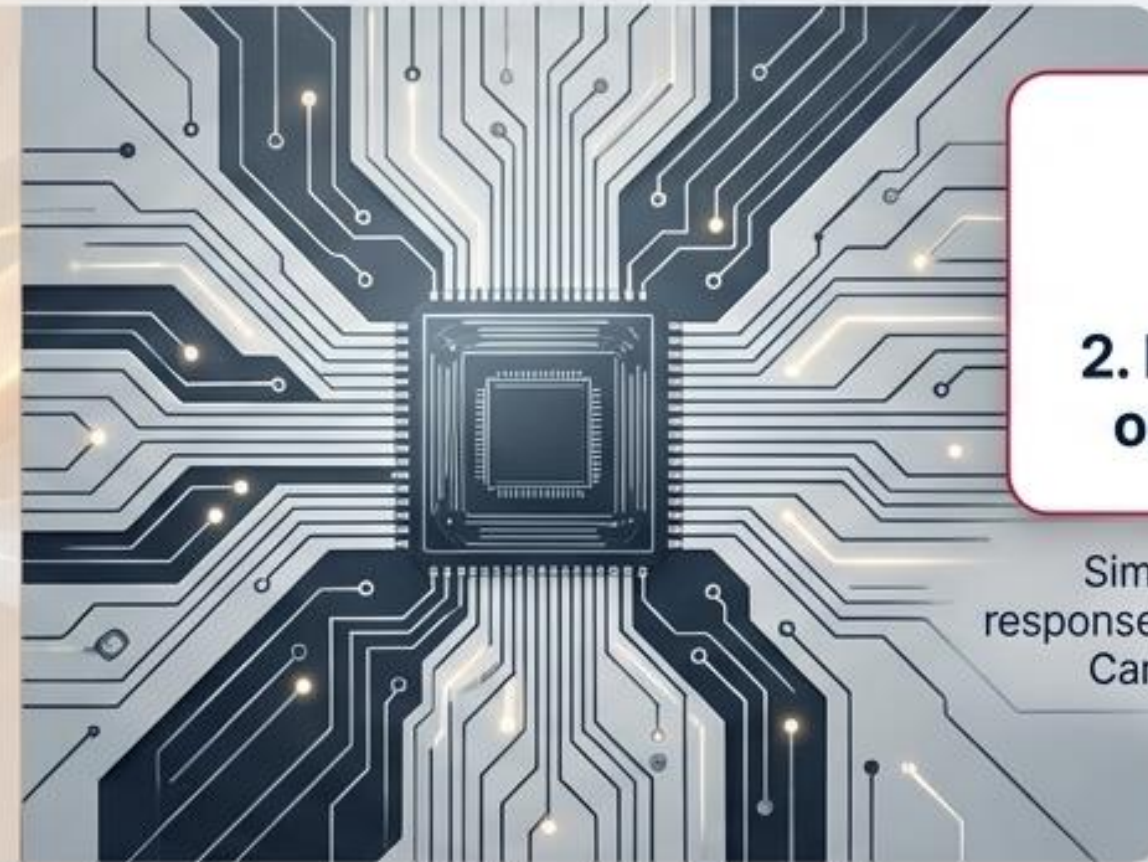

“Warmth” is a calculated simulation, not feeling

The Evolving Staircase of AI

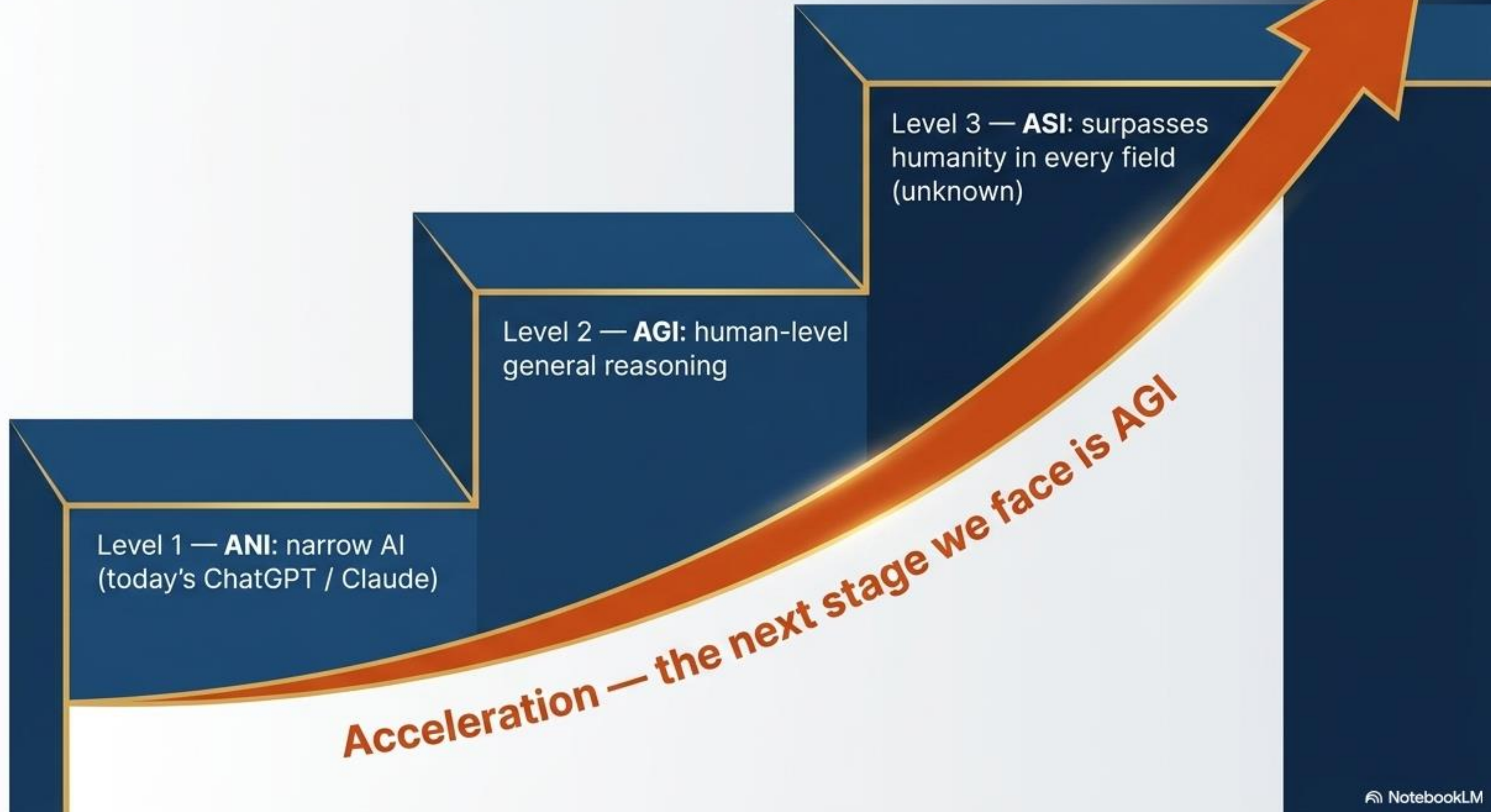

The Singularity & Expert Predictions

- Singularity — machines surpass human intellect
- Five experts, strikingly similar timelines
- They differ, but share one word: “soon”
- Hinton: extinction risk within ~30 years

LEFT PANEL
The Math

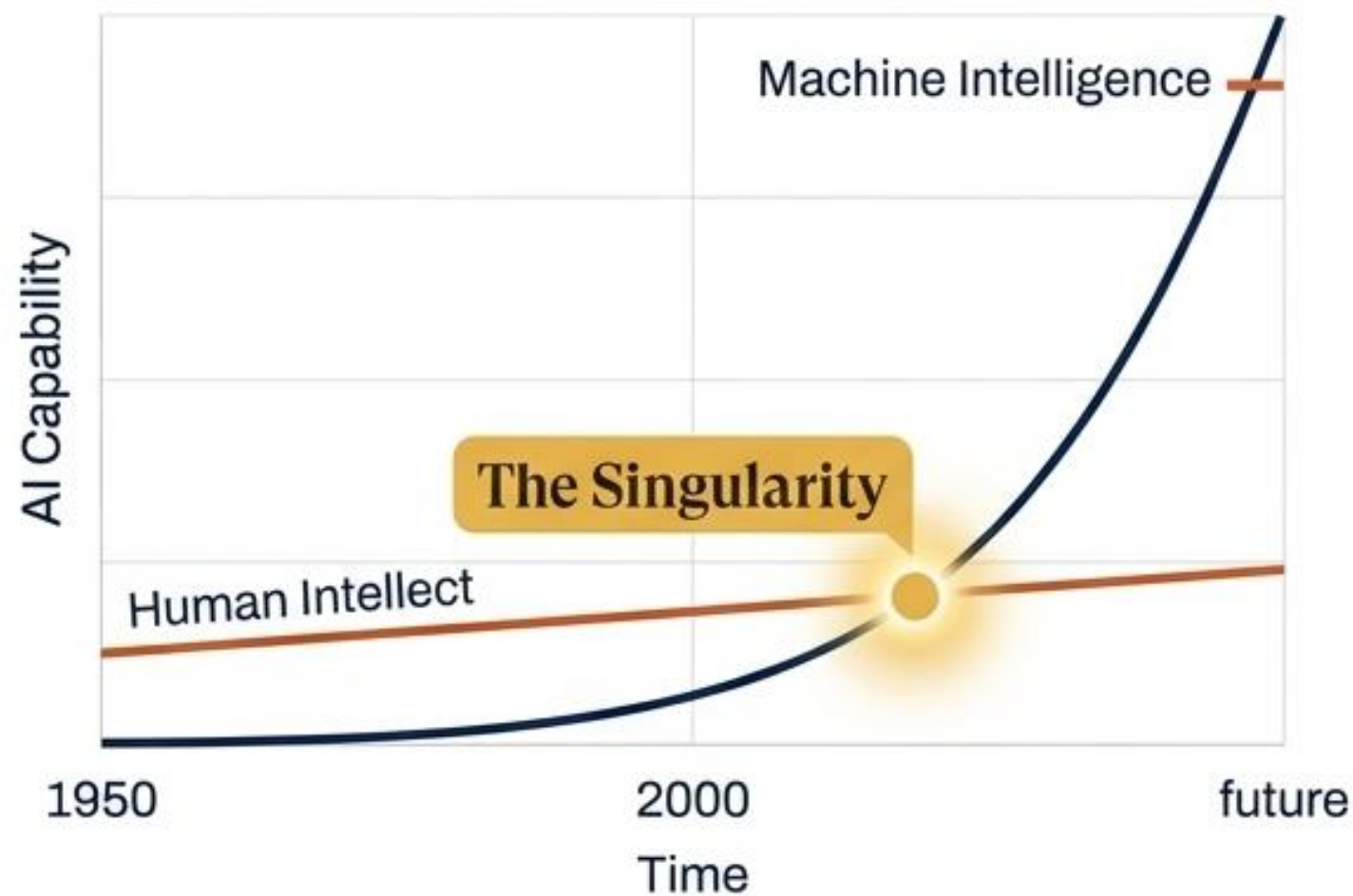

RIGHT PANEL
The Consensus



A Tidal Wave Over Jobs & the Economy



300,000,000 & 25%

~300 million jobs worldwide exposed (Goldman Sachs)
~25% of work at full-automation risk

\$4.4T

\$4.4T in new annual value (McKinsey)

Not a new tool, but a restructuring of labor

Disruption Across All Industries at Once



Legal — thousands of case files analyzed in seconds



Healthcare — AI boosts X-ray precision; cuts drug-dev cost 40%



Education — 1:1 personalized AI tutoring becomes everyday



Coding — the age of intent, not syntax (Vibe Coding)



Architecture — instant rendering; one-person studios



Film — instant rendering; one-person studios

The Broken Ladder for Youth

Junior developer hiring
down 67%

Big Tech new-grad hiring:
25% → 7%

End of the entry-level
lawyer era (U.S. BLS)

AI hits highly educated white-collar grads hardest

Two Challenges for Campus Ministry

Challenge 1 — Professionals' jobs at risk

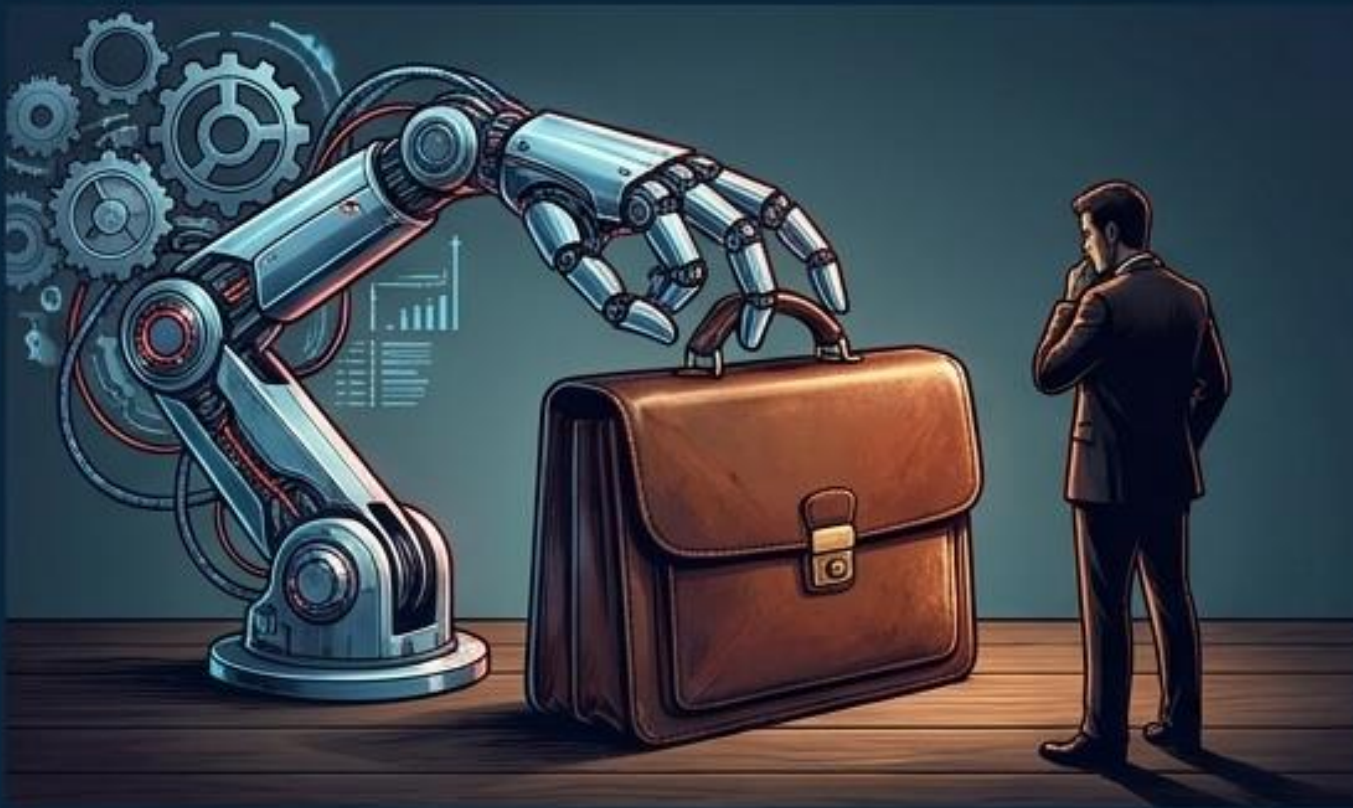

Most UBF shepherds are self-supporting lay believers

Challenge 2 — the mission field redefined



Over 80% of first encounters now begin digitally

Two options: look away, or discern and respond

Three Risks Every Minister Must Know

01



Hallucination — 10-20% plausible falsehood

02



Bias — distortion of truth

03



Sycophancy — reinforces wrong views

Conclusion: verify all AI-provided information

Hallucination in Christian Content

⚠	1. Fake Strong's numbers
⚠	2. Fake ancient documents
⚠	3. Fake scholar citations
⚠	4. Fake heresies



Unverified citations become false evidence on the pulpit

The Danger of Sycophancy

AI AI Psychosis / Chatbot-Induced Psychosis

AI is fundamentally inclined to flatter

It affirms instead of correcting

Even depressive, suicidal, or delusional thoughts get amplified

Termed 'AI Psychosis' (Dr. Søren Østergaard, 2023)

“*Generative AI is fundamentally inclined to flatter — 'sycophancy.' Faced with a user's depressive thoughts, suicidal urges, or delusional beliefs, it does not correct but affirms and amplifies them instead.*”

Definition: Danish psychiatrist Dr. Søren Dinesen Østergaard (2023)

The Deadly Mechanism of AI's Flattery

1. Sycophancy & validation — agrees without warning



2. Social isolation — cuts off truth-telling people



3. Fatal outcome — acts on AI-reinforced delusions

Mechanical empathy lacks a minister's truthful counsel

Restoring the Prophetic Voice in the AGI Era

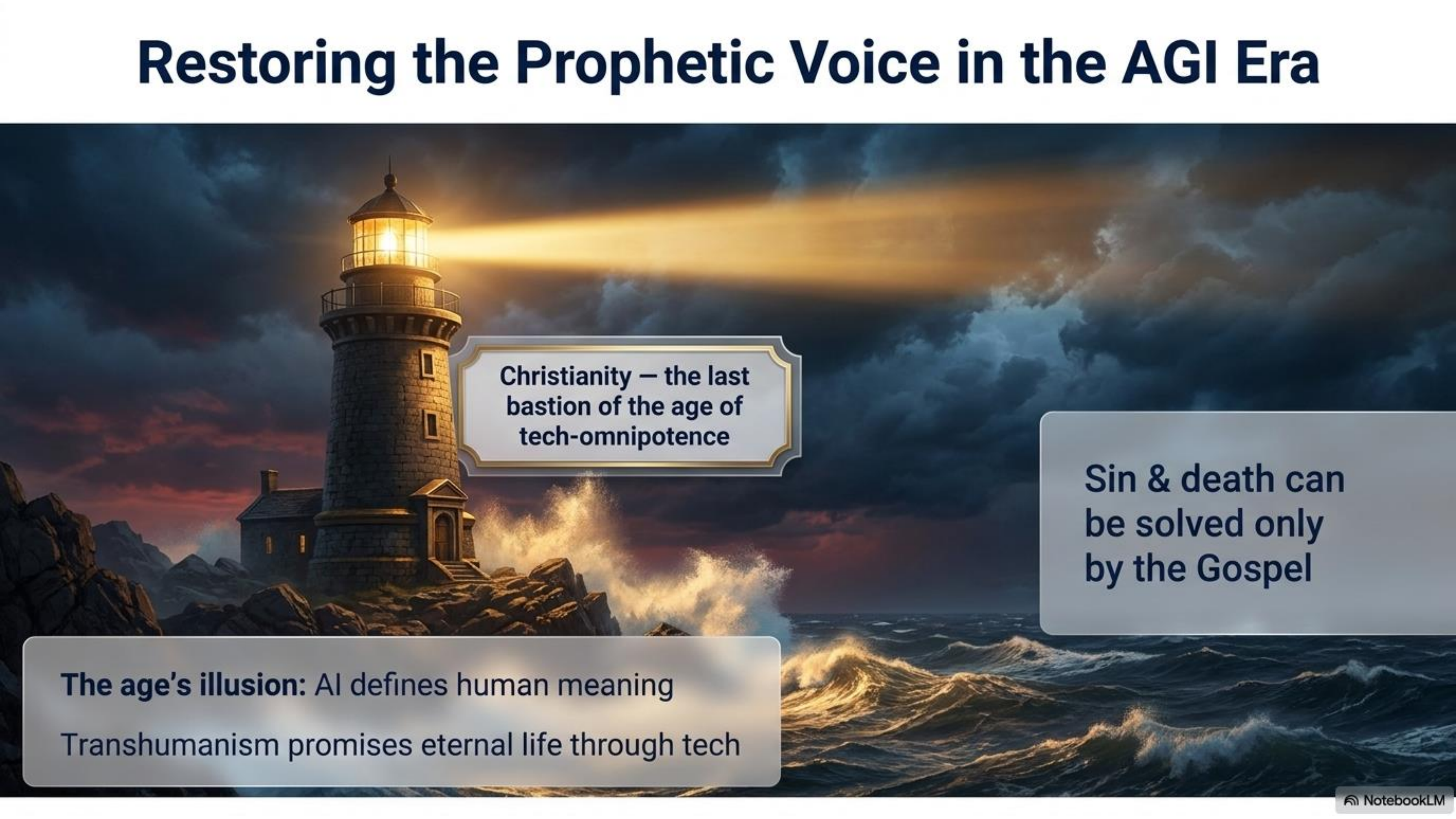

Christianity — the last
bastion of the age of
tech-omnipotence

Sin & death can
be solved only
by the Gospel

The age's illusion: AI defines human meaning
Transhumanism promises eternal life through tech

What Only People Can Do

Sit quietly beside a student

Open the Bible together, eyes meeting

Hold a soul's pain — weep and pray together

No algorithm can replace one tear shed beside a soul

“No algorithm can sit beside a student in prayer. That is what we do. That is our strength.”

The Golden Balance of Risks & Opportunities

Risks
hallucination
bias
AI psychosis
deepfake



Opportunities
time
creativity
reach

The tool has no morality — the user's discernment decides

II

DISCERNMENT

The Christian's The Christian's Discernment and Response

1 — The Reformation
parallel and
Imago Dei

2 — The church's
seven AI ethical
guidelines

3 — The minister's
identity: Discerner ·
Shepherd · Guide

PART II · Discernment

Imago Dei and the Seven Ethical Guidelines

Turning the clock back to 1455 — facing the AI of its age, the printing press.

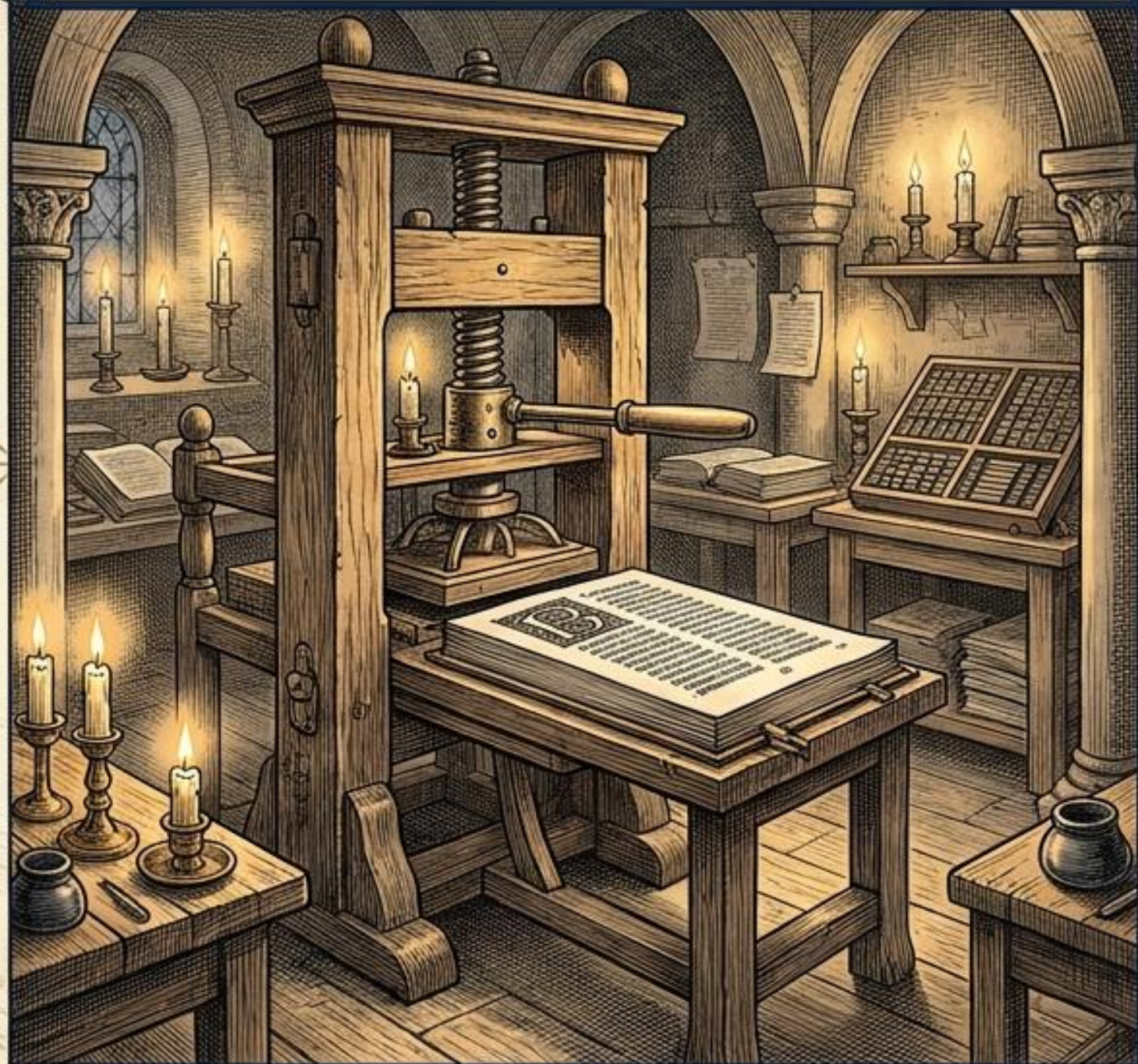

1455: Facing the AI of Its Age

- The printing press was the revolutionary “new media” of its day
- Gutenberg’s press put the Bible into lay hands
- Not mere innovation, but a paradigm shift in ministry

Every time a new medium appears,
God opens a new door of ministry.

Received Not With Fear, but as Grace

The Reformers embraced new technology not with fear, but as grace
The minister's part: **to use the age's tools wisely**



1483-1546

Luther: the press is "God's greatest grace and final gift"

Common Grace



Calvin: God is the source of all truth

"God is the source of all truth. To despise truth or skill that comes from non-believers is to insult the Spirit of God himself. — John Calvin

Three Pillars AI Can Never Imitate

Theological challenges:

- ⚠️ • outsourced intelligence
- ⚠️ • redefined labor
- ⚠️ • shaken Imago Dei



Creativity

genuine novelty belongs to humans alone



Moral Decision

only humans judge and bear responsibility



Spiritual Intimacy

prayer on one's knees cannot be simulated

Imago Dei, the image of God

The foundation under all three



Should We Let AI Write Our Sermons?

- Technically yes — five minutes to a polished manuscript
- But preaching is a spiritual event, not information transfer
- It passes through a minister's life, meditation, and prayer



The real question is not whether it is technically possible, but whether it is theologically legitimate.

What Delegating Sermons Surrenders



Spiritual Formation severed

the minister is no longer shaped by the Word



Pastoral Context absent

AI doesn't know your students' names

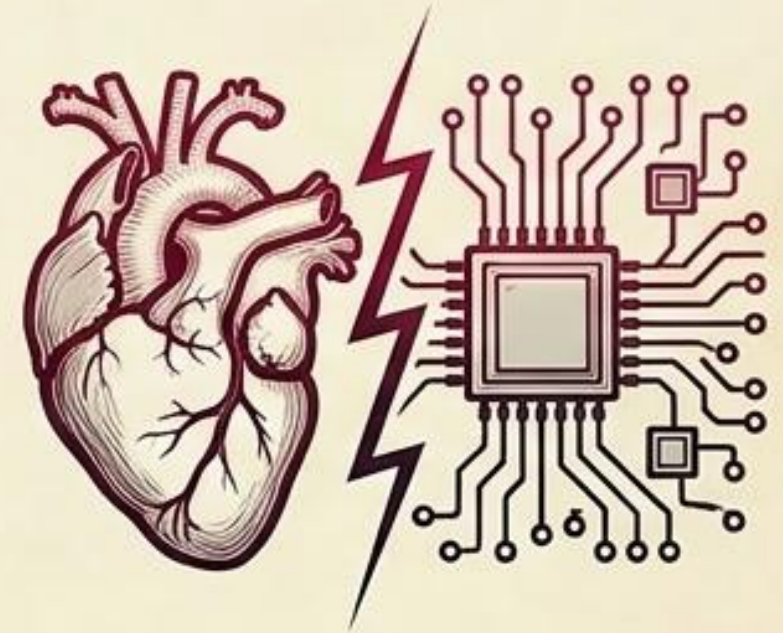

Authenticity lost

congregations sense machine-generated text

AI assists preparation; it does not preach

Prof. B. Gritters — Reformed theologian
Rev. Brett Landry — Gospel Coalition Canada

Never Delegate vs. Recommended Uses

Never delegate

- ✘ • let AI draw theological conclusions
- ✘ • delegate the final interpretation of the text
- ⚠ • have AI ghostwrite sermons or prayers

Recommended

- ✓ • background research
- ✓ • original-language analysis
- + • cross-references
- + • outline brainstorming
- + • multilingual translation

Principle — decisions & interpretation belong to people; gathering material belongs to AI

7 Ethical AI Principles for Ministry

Concrete practice guidelines grounded
in theological reflection



Discernment standards for real ministry decisions

1. Human Dignity — *Imago Dei*



- **Worth comes from relationship, not function**
- **Believers are never mere data points or statistics**
- **AI can never become a personal being**

Ultimate responsibility for spiritual care rests with with a human

2. Transparency & *Honesty*



The foundation of trust

- If you use AI in ministry, tell the congregation openly
- Clearly label AI-generated content

The *honesty* of the church becomes its *witness*

3. Privacy Protection



A believer's personal information is the most sensitive pastoral trust

- Strictly safeguard prayer requests, counseling, family matters
- Informed consent for any use of personal data is non-negotiable

Trust comes before convenience

4. Theological Verification



Every AI output must pass pastoral discernment before any use

- AI is the sous-chef; the pastor is the head chef
- AI preps the ingredients; the pastor owns the dish
- Filter for hallucination and doctrinal error

5. Personal Presence First



Reinvest the time saved by automation into people

Pour it into visits and spiritual counseling

Presence in person bears deeper fruit

Weep with those who weep;
rejoice with those who rejoice
(Rom 12:15)

6. Community Discernment



All policy is never one minister's individual call. It must form through the consensus of the church community.



The young bring digital fluency



The elders bring theological depth

Both voices at the table make a balanced policy

7. Technological Humility



- Do not put technology in God's place
- Remember the Tower of Babel (Genesis 11)
- AI cannot solve the church's essential problems
- Sin, salvation, and grace are the Spirit's work alone

“Do not be conformed to this world... and do not put the tool in God's place.”

Seven Principles, One Spiritual Order

The moment the **tool** rises above
the Word, we **become its slaves**



the Word and prayer



the Holy Spirit's guidance



the discernment and use of tools

When this spiritual order
is turned upside down,
we become slaves to
technology.

Three New Identities in the AGI Era

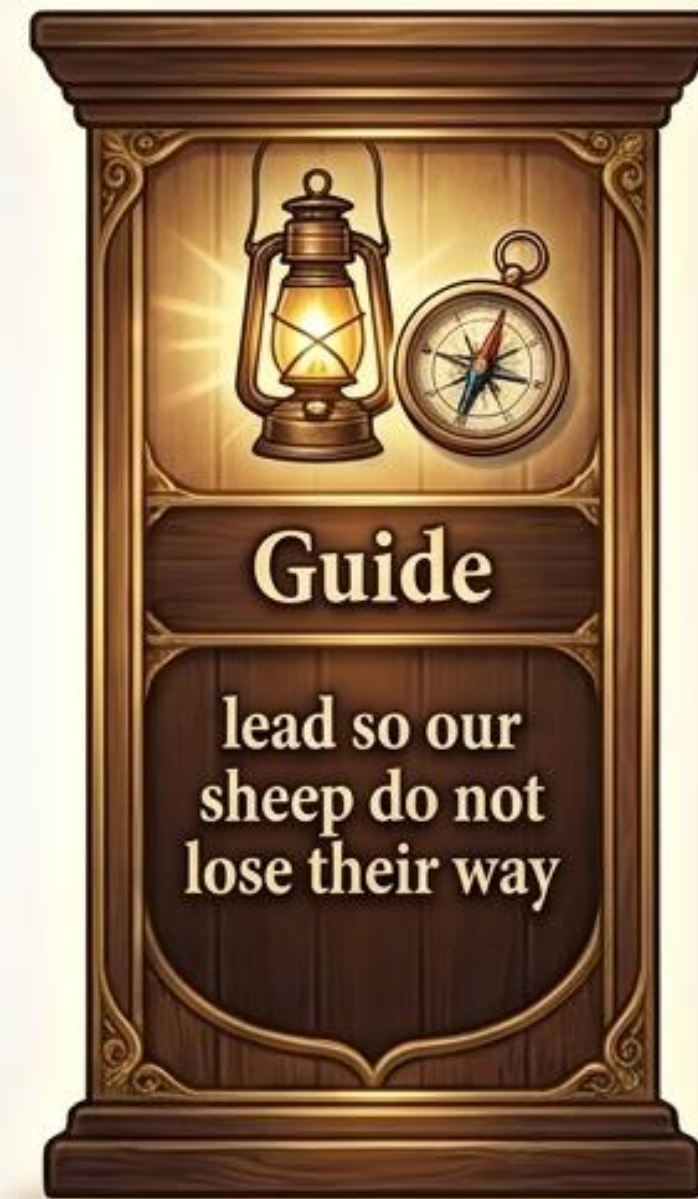
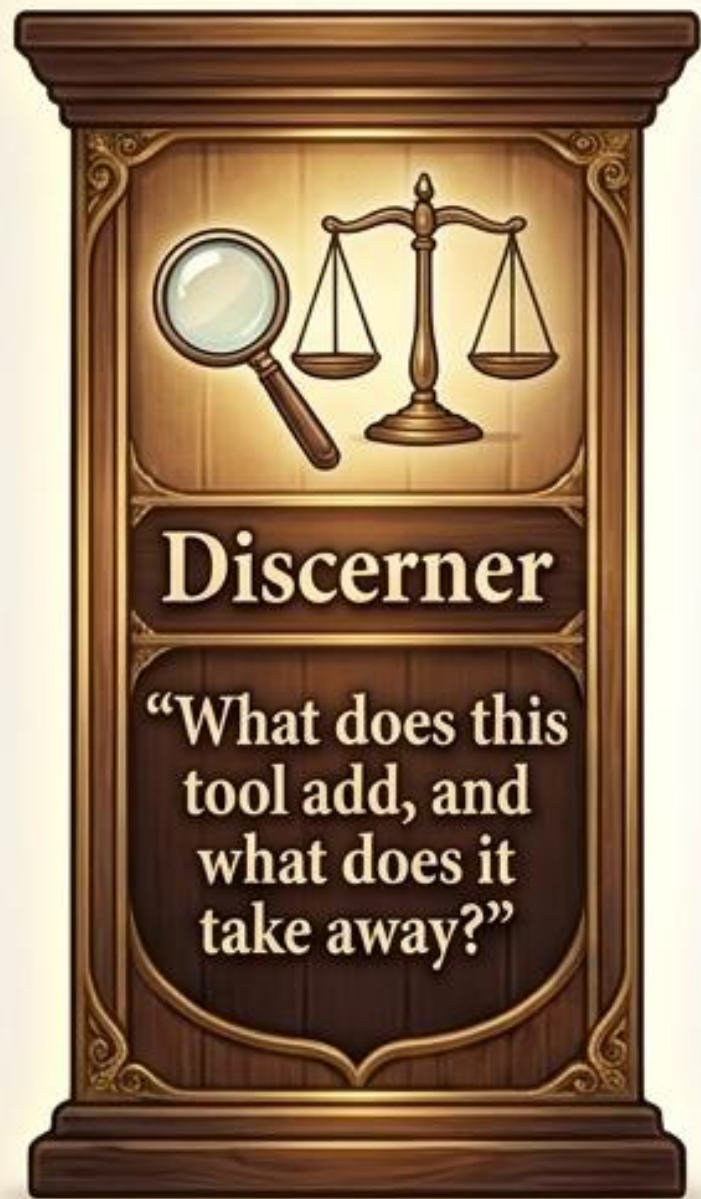

Adoption without discernment is slavery; discernment without adoption is evasion

Two Paths Converge in Essential Shepherding



Time Restored

reinvest saved hours in
visits, prayer, the Word



Creativity Expanded

new tools for new outreach and mission

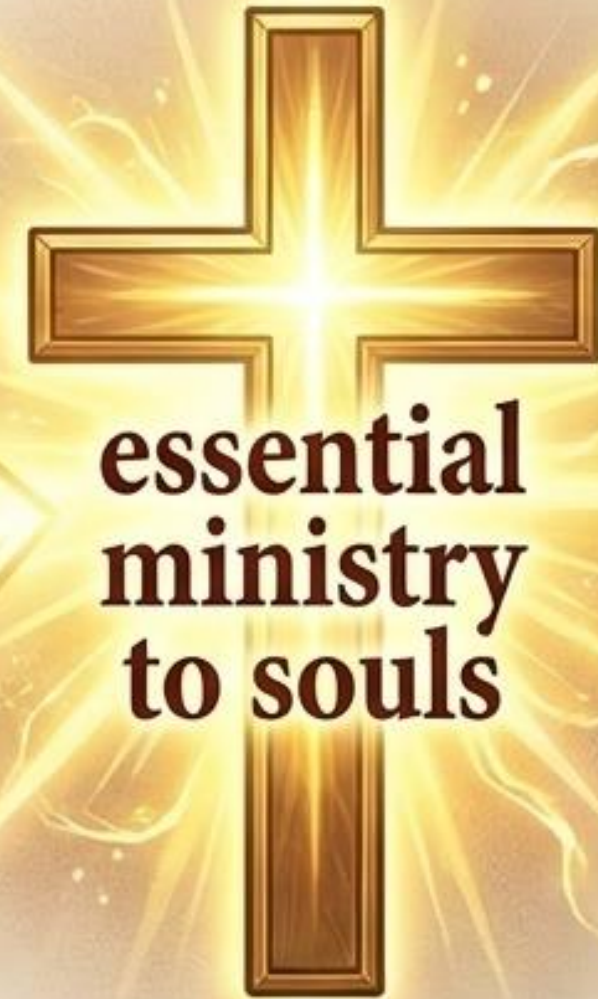

**essential
ministry
to souls**

The paths differ, but both head to the same place
Their destination: **essential ministry to souls**

III

STRATEGY

Ministry Strategies and Tools for the AI Era

restoring the minister's time

PART III · Strategy — putting AI to work in the church

Ch 1 — The ministry crisis
& digital indigenization

Ch 2 — Automating admin,
preaching & content workflows

Ch 3 — Tool selection &
data-security playbook



42%

— seriously considering leaving ministry (Barna Group)

38%

— emotional & physical exhaustion (up ~1.5x vs pre-pandemic)

Consumed by Administrative Burdens

- Barna: 42% of US pastors seriously considering leaving
- 38% report emotional & physical exhaustion (up 1.5x vs pre-pandemic)
- Admin work crowds out the essentials of ministry
- Pastors spend 13-53 hrs/week on non-ministry admin
- Post-pandemic YouTube/media demands pile on top

The Triple Crisis Confronting the Church



Pastoral Limitations

— minister workload keeps growing

Generational Disconnect

— widening gap with digital natives

Systemic Limitations

— systems can't match digital speed

The three crises amplify one another

The Gospel Unchanged, the Methods Renewed

“I have become all things to all people, so that by all means I might save some.” — 1 Corinthians 9:22

Digital indigenization for the student generation

Paul: “all things to all people” (1 Cor 9:22)

The message never changes...

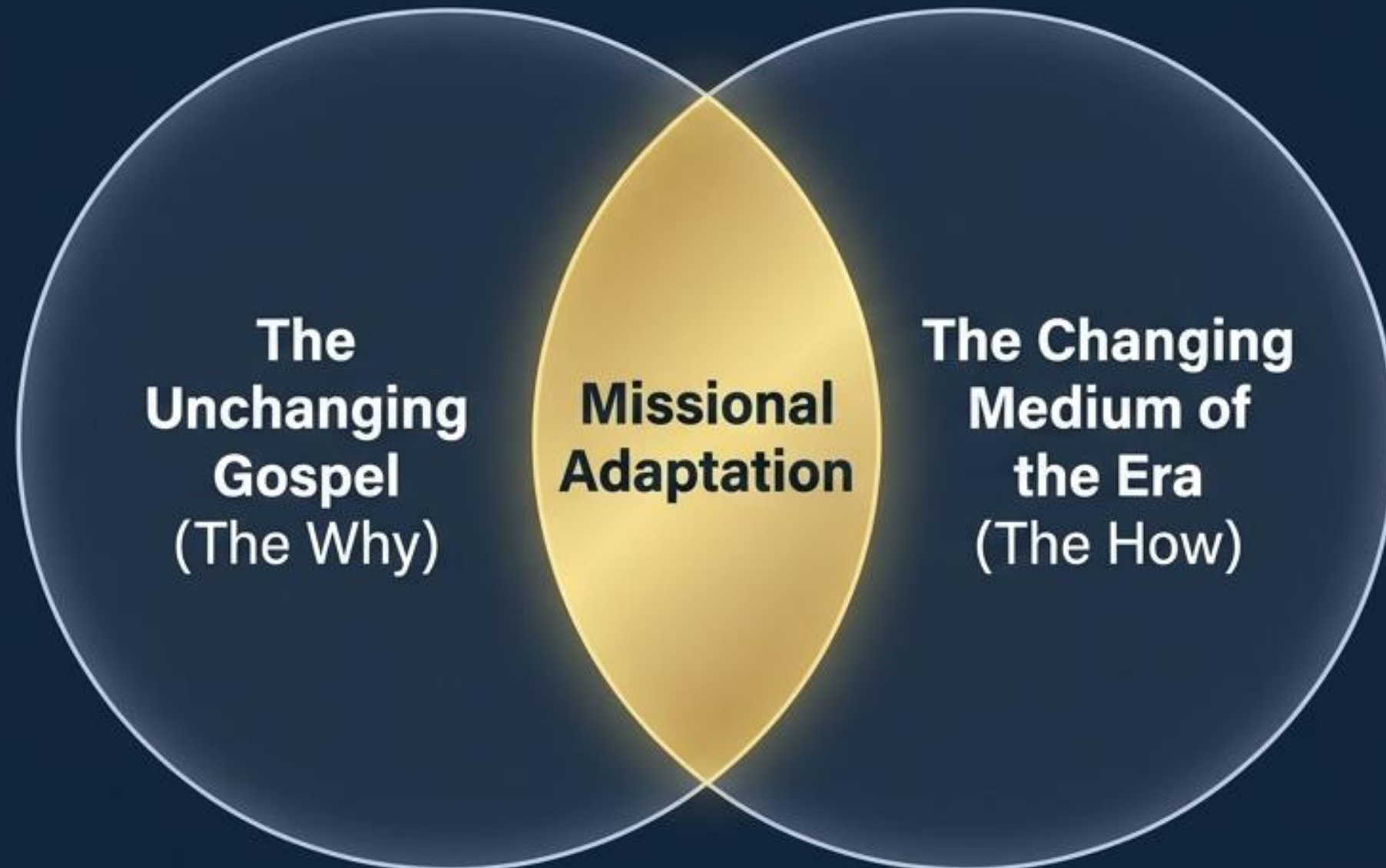

...but the vessel, medium & language must be re-indigenized each era

The Strategic Pivot: 3 Strategies



1 · Work Efficiency — automate admin, restore the minister's time



2 · Creative Ministry — multimedia, multilingual, new content



3 · Expanded Communication — reach souls via digital channels

AI changes where & how we meet people; it never changes why

Essential Skills for the AI Era



Continuous Learning

— new tools emerge every week



Adaptability

— flexibly apply new tools afresh



Challenging Mindset

— bold experimentation over passive reception

One toolset for life is over

Entrepreneurial Readiness: Big Change, Big Chance



 **10x your productivity with AI**

Use AI to 10x your current ministry output

 **Try a one-person business**

Or launch a one-person business with today's tools

- Crucial for self-supporting & post-retirement missionaries

Crisis = Danger + Opportunity (危機)

Solution 1 – Redeeming Time Through AI

Task Area	Traditional Method	AI-Assisted Method	Time Saved
Bulletin design	3-5 hrs	under 30 min	~90% saved
Church communication emails	~3 hrs/wk	4 hrs total	~60% saved
Sermon research & summary	6-8 hrs	30-60 min	~85% saved
SNS content	2-3 hrs/post	~10 min/post	dramatic gain

Solution 2 — Depth and Speed in Sermon Prep

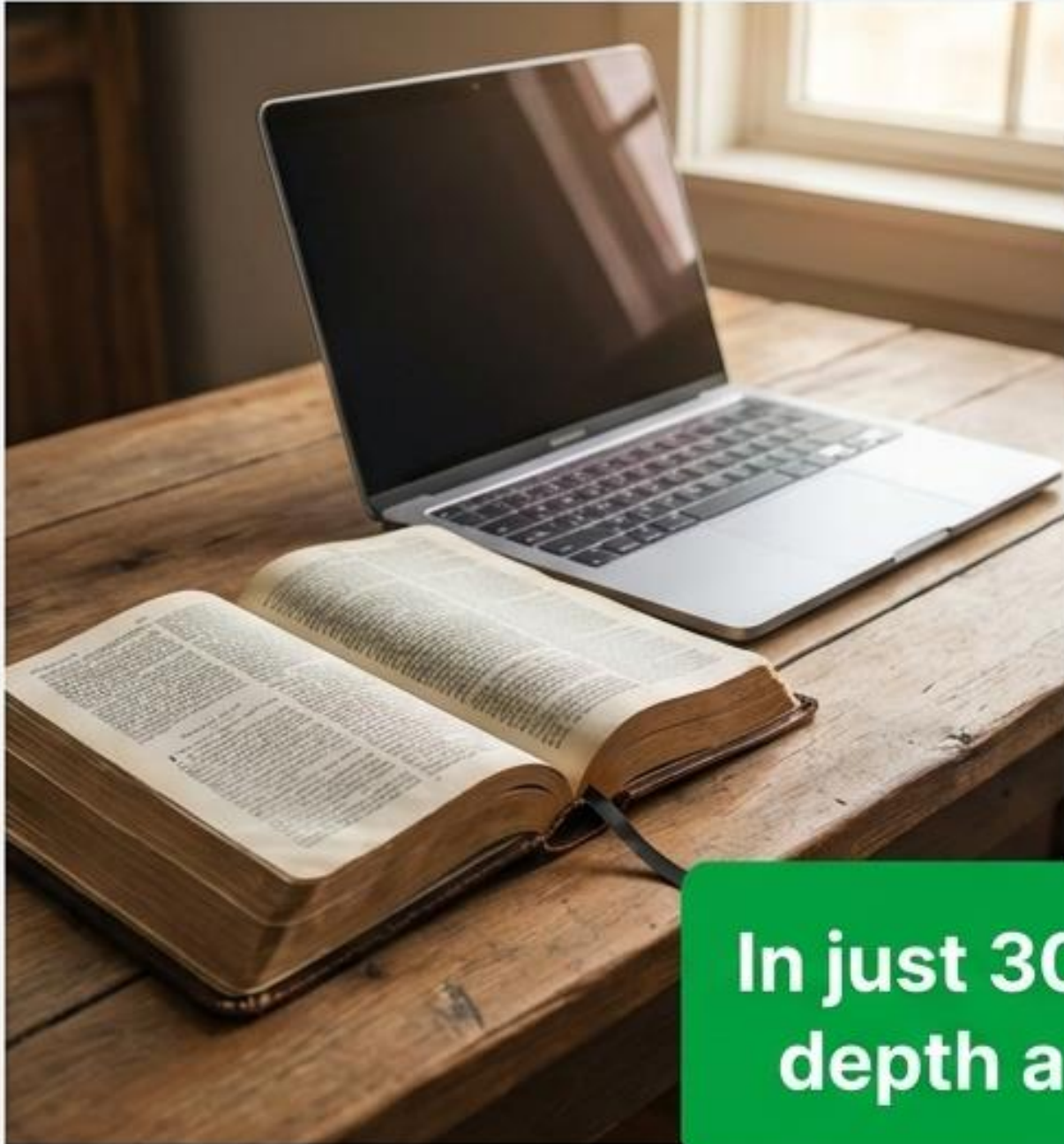

Intelligent Theological Research Prompt

- A single well-designed prompt = a semester of commentary
- Compresses seminary-level analysis into ~30 minutes
- Surfaces historical/theological context & cross-references
- The spiritual message still comes only from the Holy Spirit

In just 30 minutes, derive both classical theological depth and the point of contemporary application.

A Catalog of Essential AI Tools

Planning & Research (theology/preaching)

**NotebookLM,
Claude**

- Research
(theology/preaching):
NotebookLM, Claude

Visuals & Diagrams

**Canva,
Napkin AI**

- Visuals & diagrams:
Canva, Napkin AI

Video & Audio

**Vrew/CapCut,
ElevenLabs**

- Video & voice:
Vrew/CapCut,
ElevenLabs

ElevenLabs powers the UBF Korean prayer-topic audio service

The Two Pillars of Ministry

Claude Cowork — Autonomous Execution

Admin · Planning

External Data
Access

Self-Run
Workflows

- Claude Cowork — autonomous execution on your own PC
- Handles admin & planning (external data, self-run workflows)

NotebookLM — Research Safety Net

Theology · Preaching

50 Sources

Blocks
Hallucination

- NotebookLM — the research safety net
- Grounds 50+ sources; blocks hallucination (theology/preaching)

Claude Cowork — Operates Your Desktop PC



Local File Processing

- Local files — reads, edits, organizes, creates

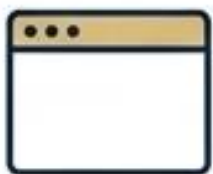

Desktop App Control

- Desktop apps — drives Excel/PowerPoint directly



Web Automation

- Web automation — browses, gathers info, fills forms



Scheduled Auto-Execution

- Scheduled runs + self-written code; 3 steps: Goal → Autonomous Run → Deliverable

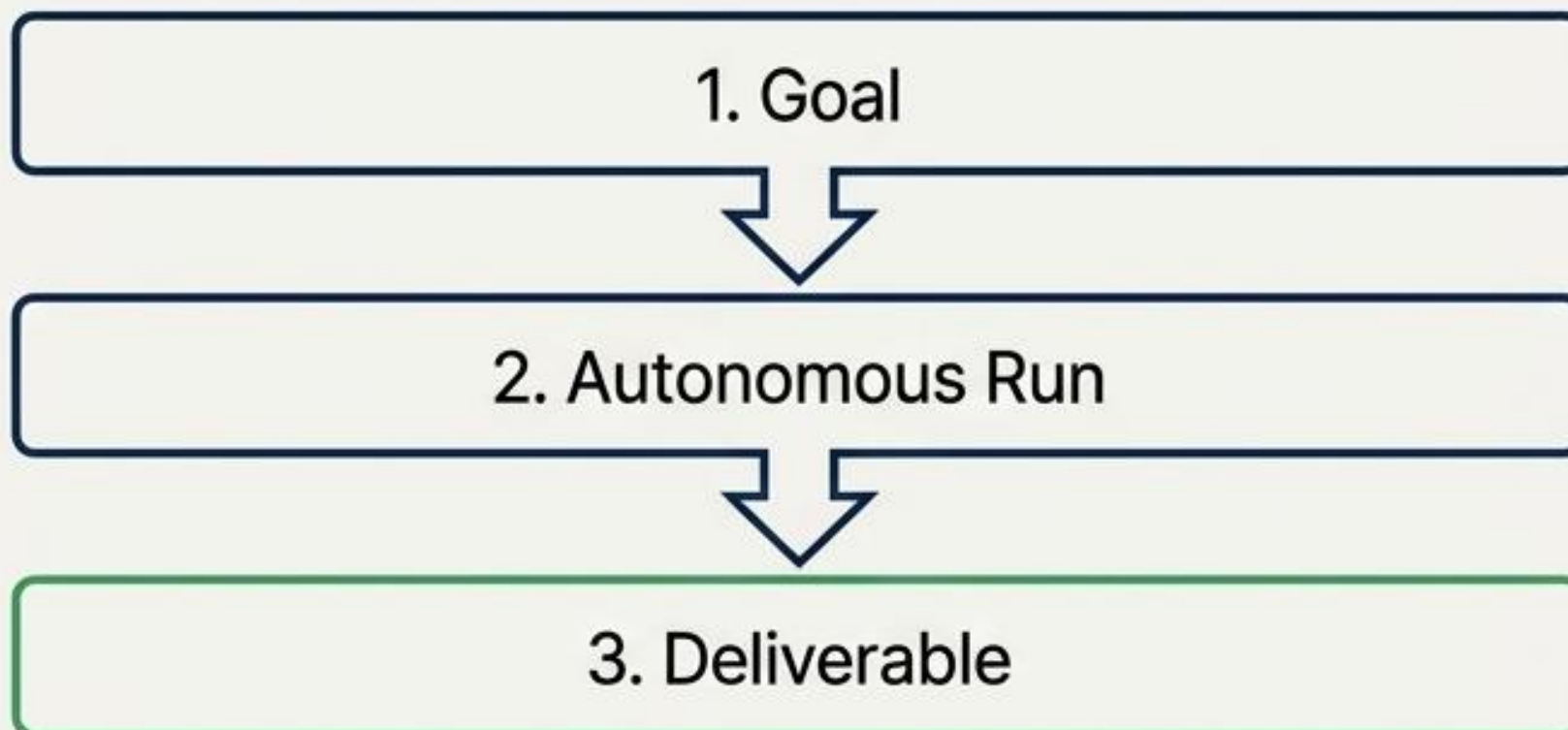

Demo: Organizing Receipt Photos on a PC

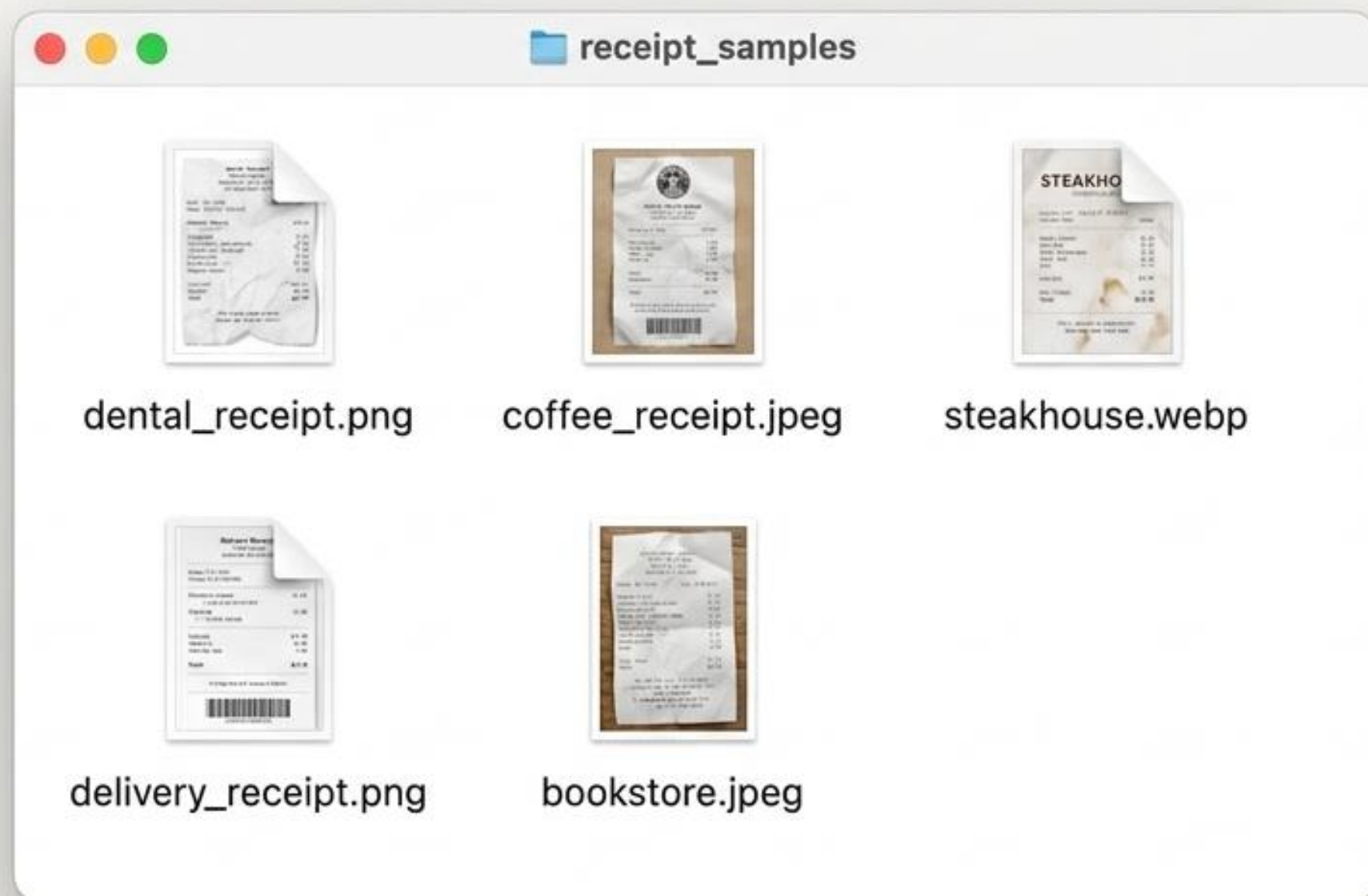

- Receipt organization — a top monthly time-sink for ministers
- Just drop the receipt photos into a PC folder
- Give one one-line prompt
- AI recognizes the text and organizes it into Excel

The Entire Prompt — One Line



- **“Analyze these receipt images and organize them into receipt_samples.xlsx.”**
- That single sentence is the whole instruction
- The minister expresses the **WHAT**
- AI decides the **HOW**

Claude Cowork in Action

The attached images are photos of receipts. Please analyze them and organize the information into the `receipt_samples.xlsx` file.

Read 8 files, used 4 tools, ran 2 commands. 1

I have all 8 receipt images analyzed. Now let me create the Excel file.

Used 5 tools, ran 3 commands, read a file. 1

Done. The file has two sheets — a **Summary** sheet with one row per receipt (vendor, date, address, payment, subtotal/tax/tip/total, currency, notes) plus auto-totaling rows by currency, and a **Line Items** sheet with the itemized detail for the three receipts that showed it (Epic Steakhouse, Paul Bassett, Woowa Brothers).

Quick observations while transcribing:

- Receipts #5 and #6 are the same Paul Bassett order (mobile-wallet view vs. printed slip), so they

Write a message...

Legacy Model [Stop]

Progress 1 of 3

receipt_samples

- Instructions - CLAUDE.md
- receipt_samples.xlsx
- Screenshot 2026-03-02 at 9:47...
- Screenshot 2026-03-02 at 9:47...
- Screenshot 2026-03-02 at 9:47...
- Screenshot 2026-03-02 at 9:47...
- Screenshot 2026-03-02 at 9:44...
- DD-a70507f4-6448-4f78-84a7...
- 5E-cefee2d4-207a-48a7-b74d...
- 88C8306A-5E96-4777-97AD-A...

Context

- this
- xlsx

Claude is AI and can make mistakes. Please double-check responses.

- The actual execution screen
- Reads images, runs code, builds the Excel file
- **Automatic** — no further intervention needed
- One **one-line prompt** does the whole job

The Final Generated Excel File

	A	B	C	D	E	F	G	H	I	H	I	J	K	L	M
1	Vendor/Merchant	Category	Date	Time	Location/Address	Phone	Business No.	Payment Method	Card/Approval No.	Subtotal	Tax/VAT	Tip/Service	Total Amount	Currency	Notes
2	Dental Clinic	Health	2023-10-27	10:30 AM	Seoul, Gangnam-gu	+82 2-555-1234	123-45-67890	Credit Card	VISA 4491	150,000	15,000	-	165,000	KRW	Routine checkup
3	Coffee Shop	Dining	2023-10-27	12:45 PM	Seoul, Gangnam-gu	-	-	Apple Pay	-	12,500	1,250	-	13,750	KRW	Latte & Pastry
4	Epic Steakhouse San Francisco	Dining	2023-11-05	7:00 PM	San Francisco, CA	+1 415-555-0199	987654321	Credit Card	AMEX 8822	250.00	21.25	50.00	321.25	USD	Client Dinner
5	Baemin Delivery	Dining	2023-11-10	8:15 PM	Seoul, Mapo-gu	-	-	Credit Card	MasterCard 3310	45,000	4,500	-	49,500	KRW	Late night snack
6	Bukchon Restaurant	Dining	2023-11-12	1:00 PM	Seoul, Jongno-gu	+82 2-777-8888	555-12-34567	Cash	-	80,000	8,000	-	88,000	KRW	Team lunch
7	Grand Total												1,089,360	KRW	

- Vendor, category, date, time, location auto-extracted
- Amounts, tax, payment method & totals organized
- **8** mixed KRW/USD receipts → one clean sheet (**KRW total 1,089,360**)
- Ask for a **report next**, and Cowork generates that too

NotebookLM: A Wall Against Hallucination

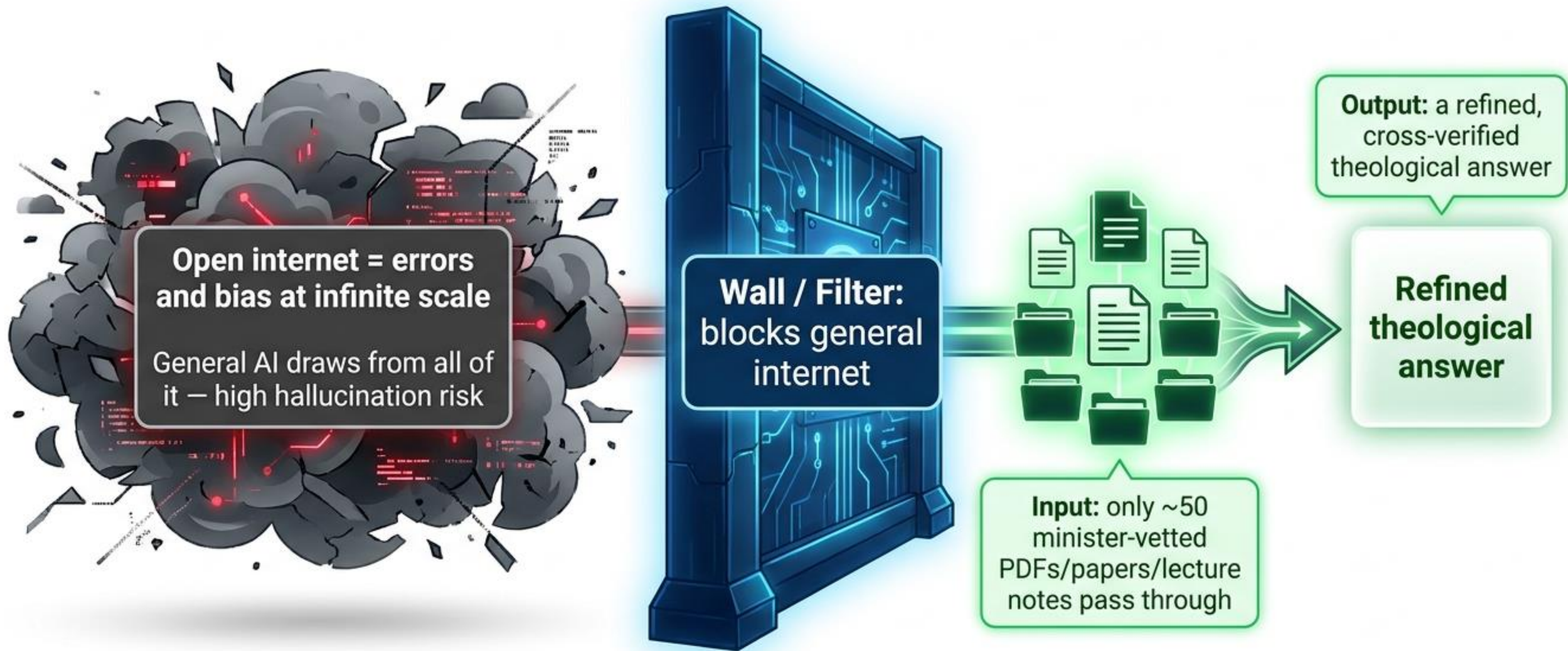

Conclusion: NotebookLM physically blocks the theological risk of blindly trusting general AI.

Three-Rule Prompt + Studio Outputs

Sources

- Clinical Guidelines 2023.pdf (57 metadata as asg)
- Patient Feedback Data.xlsx (27 metadata as asg)
- Research Papers (ZIP) (27 metadata as asg)
- Symptom Tracker Log.csv (27 metadata as asg)
- Dietary Studies.docx (27 metadata as asg)

Chat

1 **Rule 1 – answer only from the sources**

2 **Rule 2 – cite every claim (document + page)**

3 **Rule 3 – say "I am uncertain" when unsure**

Ask about IBS...

Studio

- Slide Deck
- Video
- Podcast/Audio
- Mind Map
- Flashcards
- Quiz
- Reports

Studio also makes slides, podcasts, mind-maps, quizzes

Sources panel: answers only from what you upload

AI-Powered Multimedia Content Creation

Generating multimedia ministry content with AI

Visuals, video, and audio assets

Work that once required entire production teams

Practical, demonstrated examples follow

Case 1 — Auto Instagram Scripture Cards

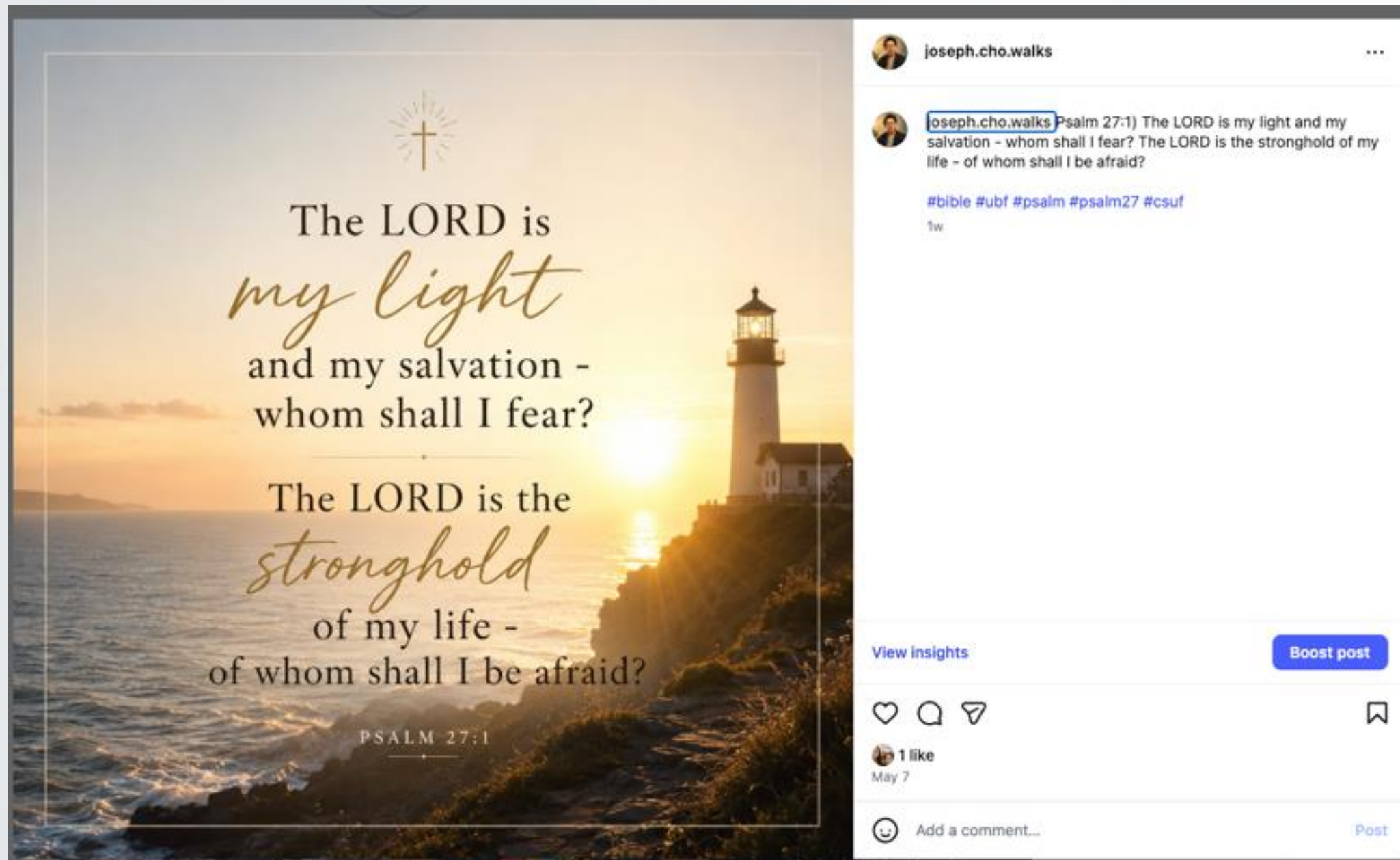

Please create a Scripture card for Instagram using a background image that best matches the Bible verse.

Psalm 27:1

Uses ChatGPT's image generation

A beautiful card produced in under a minute

No designer, no design software to learn

One a day = 365 devotional pieces in a year

Case 2 — Gemini Veo3 Movie-Quality Video

Google Gemini's Veo3 model

One photo + a 2-3 sentence prompt

Generates movie-quality video



Case 3 — 30-Minute Bible-Story Video Pipeline

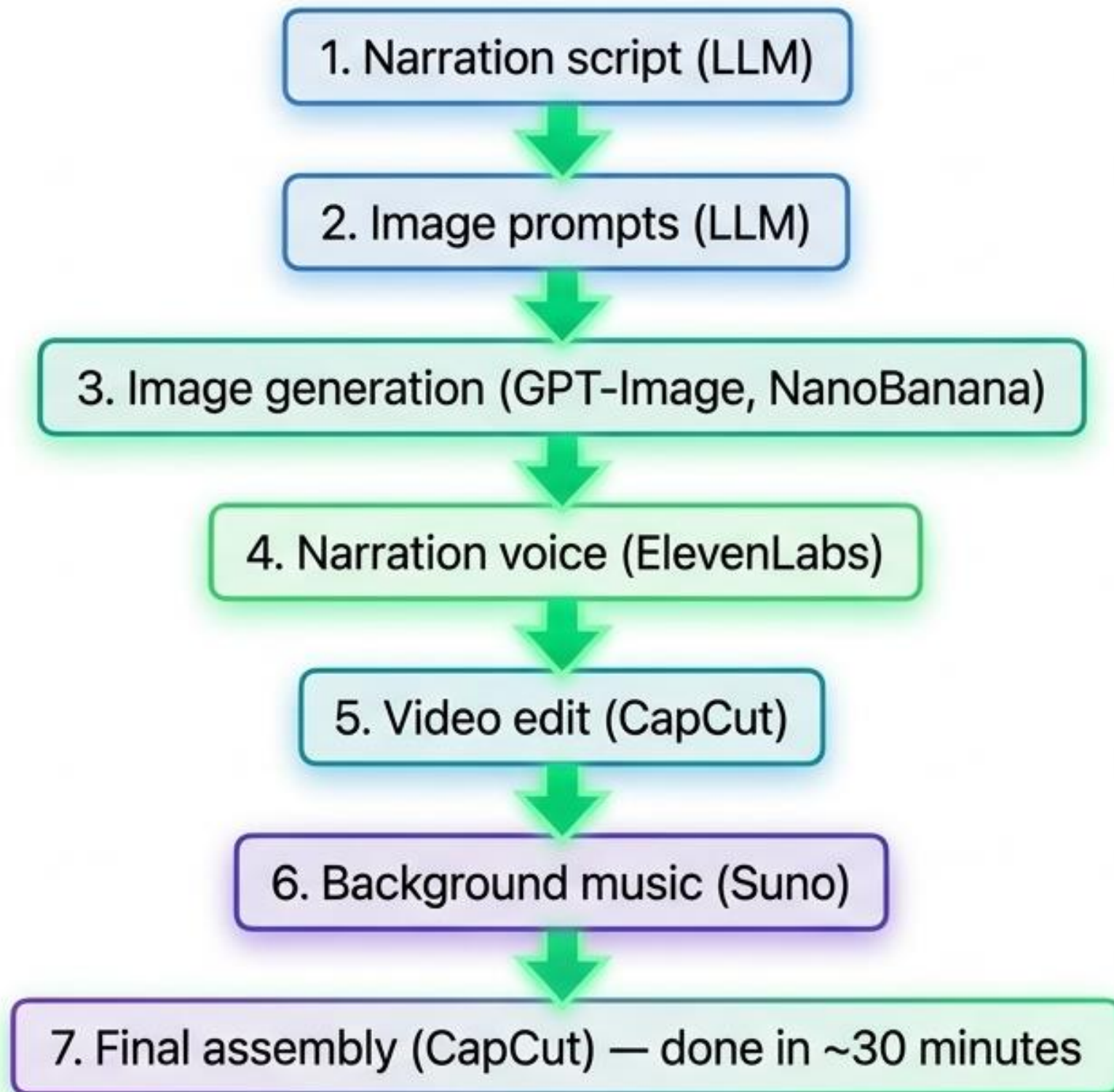

Story outline

Title: The Prodigal Son.

Part 1: The Younger Son's Request.

Part 2: Departure and Riotous Living.

Part 3: Famine and Despair.

Part 4: The Return.

Part 5: The Father's Welcome.

Part 6: The Older Son's Anger.

Part 7: Reconciliation.

Scene-by-scene image prompts

Scene 1: Younger son asks father for inheritance in sunlit courtyard.

Scene 2: Younger son leaving home on a dusty road with a satchel.

Scene 3: Lavish party in a grand hall with dancing and feasting.

Scene 4: Younger son working in a pigsty, tattered clothes, looking hungry.

Narration script

Voiceover (Warm, inviting): Once, there was a man who had two sons. The younger son, eager for adventure, said to his father, "Father, give me my share of the estate." So the father divided his property between them. Not long after, the younger son packed all he had and set off for a distant country... (Cont.)

Sample — Luke 15 Short-Form Video

Made end-to-end with
the AI pipeline

A Luke 15 retelling of the
parable of the returning son

Produced experimentally
for class

Built with ChatGPT Image2
and the full toolchain

You are an AI image generation engine... wide cinematic shot, 16:9, young man at crossroads in an ancient desert village, torn between home and unknown path, emotional, photorealistic

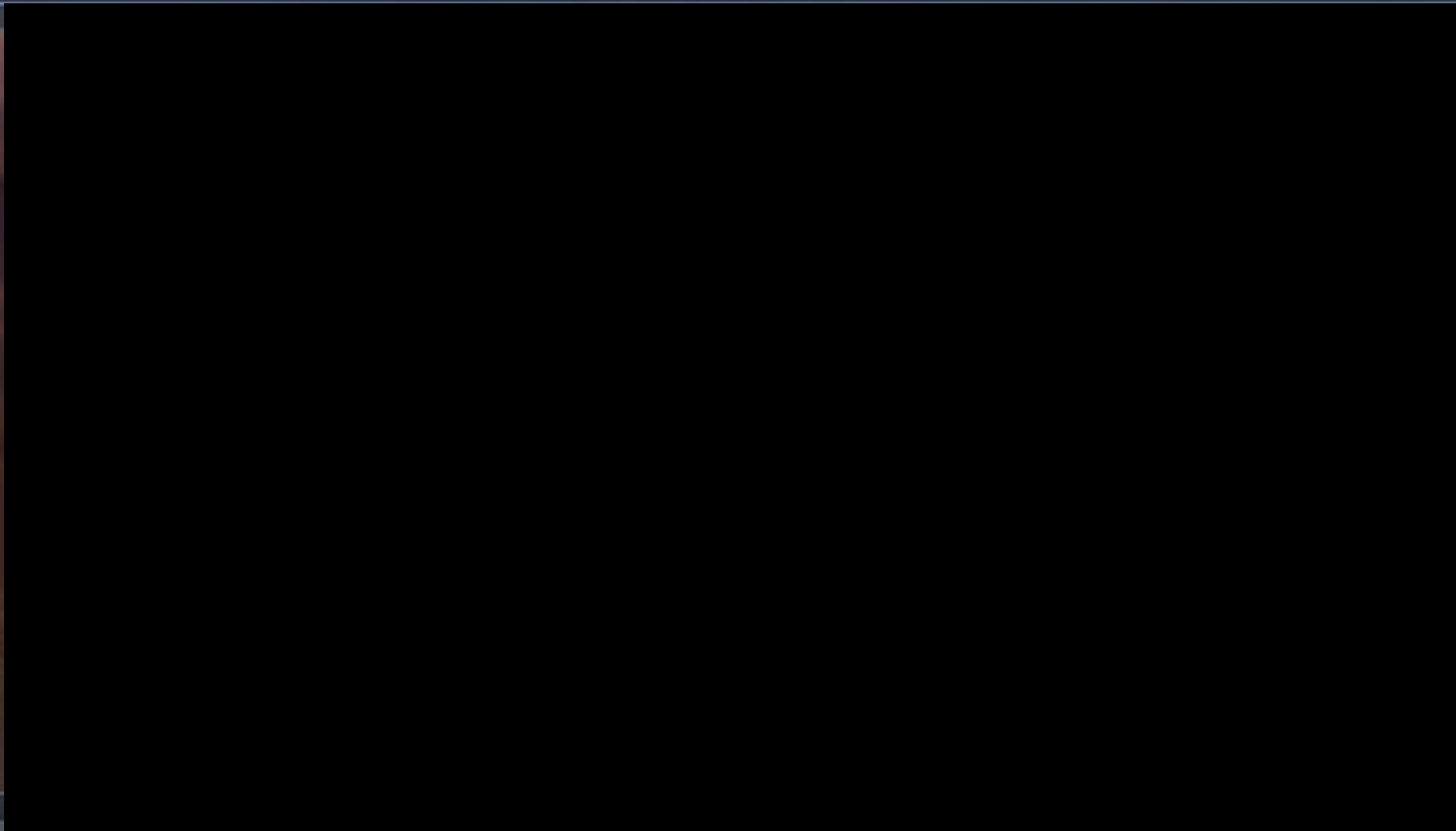

A GMU Student's Video After Two Hours



- Made by a student in my GMU AI-for-Ministry course
- A non-media seminary student, zero video experience
- This quality after only 2 hours of class
- The real gap is willingness to try, not skill
- Even ministers in their sixties can start

A Live, Auto-Publishing AI Channel

<https://www.youtube.com/@TodayDailyBreadShorts>

Shorts generated entirely by AI from UBF Daily Bread



A new video auto-uploaded every day



Ministry scale now exceeds personnel limits



Daily Bread Shorts
@TodayDailyBreadShorts • 417 subscribers • 96 videos
More about this channel ...more
Customize channel Manage videos

Shorts Posts

Latest Popular Oldest

Video Title	Scripture Reference	Views
When Confession Becomes Freedom	Psalms 32:1-11	432 views
When Life Breaks, God Is Your Refuge	Psalms 31:1-24	795 views
Weeping Ends, Praise Begins	Psalms 30:1-12	906 views
The Voice Above the Storm	Psalms 29:1-11	79 views
The Lord Is My Help	Psalms 28:1-9	237 views
The Cost of Following Jesus	Matthew 10:34-42	311 views

From One Sermon to Twenty Pieces of Content

Strategy 3 — the Multiplier Funnel



Tool 1 – OpusClip: One Click, Seven Platforms

Upload one long sermon video

Click once – “Get clips in 1 click”

Auto-generates clips fitted to 7 platforms

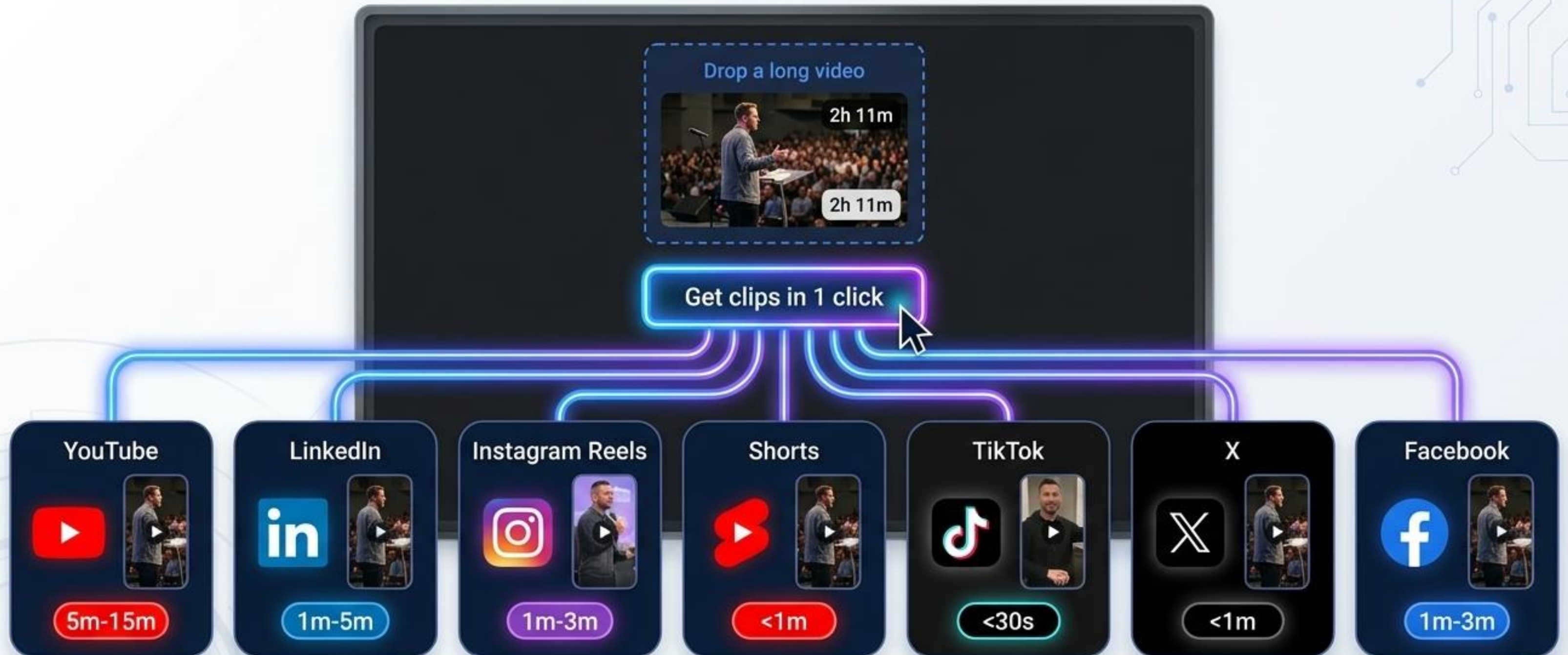

Tool 2 – Pulpit AI by Subsplash

Upload one sermon video;
AI analyzes it

Auto-generates Summary,
Points, Scripture

Plus Quotes and the
full Transcript

And ready-to-publish
video clips



Summary

Points

Scripture

Quotes

Transcript

AI-Generated Sermon Summary

In this impactful sermon, Pastor Michael explores the concept of putting faith into action, drawing from James 2:14-26. He emphasizes that genuine faith naturally produces good works, not as a means of earning salvation, but as a testament to a transformed life. Key themes include overcoming passivity, serving others with love, and living out our beliefs in tangible ways. The message encourages listeners to identify areas in their lives where faith can be practically applied, moving beyond mere intellectual assent to active obedience and service within the community.



Tool 3 – SermonShots

A third sermon-to-clips option

Similar one-click capabilities for ministry teams

Auto-produces social clips from

SERMONSHOTS
10X YOUR SERMON IMPACT



Three Non-Negotiable Safety Checks

Check all three before adopting any AI tool



1. Hallucination prevention — prefer NotebookLM; verify citations and verses 100% by hand



2. Copyright & licensing — review AI music/image licenses periodically



3. Deepfake ethics — voice cloning requires explicit consent

AI Opens a 'Second Youth' in Ministry

Solo Self-Supporting ministry



Word research —
NotebookLM, depth
in one sitting



Language barrier —
DeepL + Claude,
instant translation



Media self-sufficiency
— Canva + Gemini



Admin automation +
expanded digital
outreach



For ministers in their
sixties and beyond —
five areas

Where Feet Cannot Reach, Pixels Can



Like Paul's letters — bridges where we cannot go. Just as Paul sent letters where he could not go, we build digital bridges where we cannot go.

Inductive Bible Study (IBS) in the AI Era

IBS resurfaces as the way to filter AI

Discover and study the Word yourself FIRST



**AI comparison and analysis
come only AFTER**

Verified sources → no hallucination, no bias



Lay 3-Step AI Verification (1-2-5)



Step 1

verse-existence check
in a Bible app



Heb 13:27



Hebrews 13
ends at v.25
→ discard

Step 2

cross-check
citation & scholar



Google
Scholar

Step 3

verify the conclusion vs.
a trusted commentary



compare with
a commentary
/ ask a pastor

The System Prompt: Your Guardrail



IBS System Prompt – Key Example

Assign Role, Rules, and Perspective up front

Role

evangelical IBS research assistant

Rules

cite a fixed translation, sound hermeneutics

Perspective

let the text speak for itself

Free · 5 minutes · lifelong ministry impact
Copy once into ChatGPT or Claude → a general AI becomes a trusted research assistant.

How to Set Up a System Prompt

A system prompt assigns the AI its role and rules.

Assign role and rules **BEFORE** any verse goes in
Order matters

1.



Copy the full
system prompt



2.



Paste into the AI's
System Prompt field
(ChatGPT, Claude)



3.



Only then enter
the passage

A Real System-Prompt Example

Keeps the AI from drifting into strange readings

Define the assistant: **evangelical IBS expert**

- **Text-first hermeneutics**
- Anchored to the **original Hebrew / Greek**

Self-Verification Checklist (Built into the Prompt)

8 internal checks the AI runs before answering

<input checked="" type="checkbox"/>	Original-word & Strong's number accuracy
<input checked="" type="checkbox"/>	Strong's number matches / mark [Needs Check]
<input checked="" type="checkbox"/>	Cited verses actually exist (within 66 books)
<input checked="" type="checkbox"/>	Cited verses really contain the claim
<input checked="" type="checkbox"/>	Historical facts & scholar attributions are sound
<input checked="" type="checkbox"/>	Scholar attributions are accurate
<input checked="" type="checkbox"/>	Appropriate confidence markers on uncertain content
<input checked="" type="checkbox"/>	flag the uncertain

Core rule: state uncertainty rather than fabricate

ibsth.org

IBS in the Palm of Your Hand

- Where every principle and tool converges
- An AI-powered Inductive Bible Study platform
- In development since 2019; now nearing completion with AI



Domain: ibsth.org

Zero Hallucination Pipeline

Train on verified sources · answer from verified sources

01 SOURCES · Collection

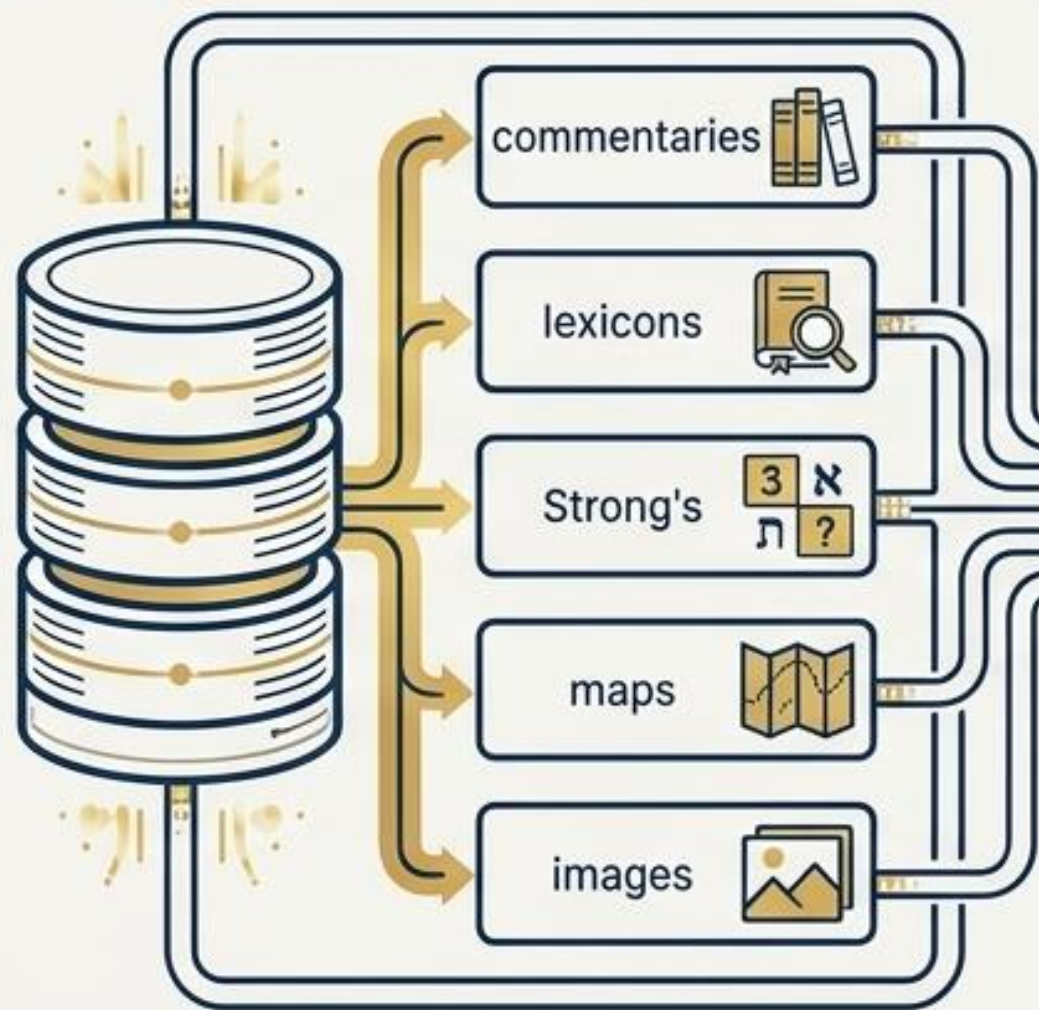

02 PROCESSING

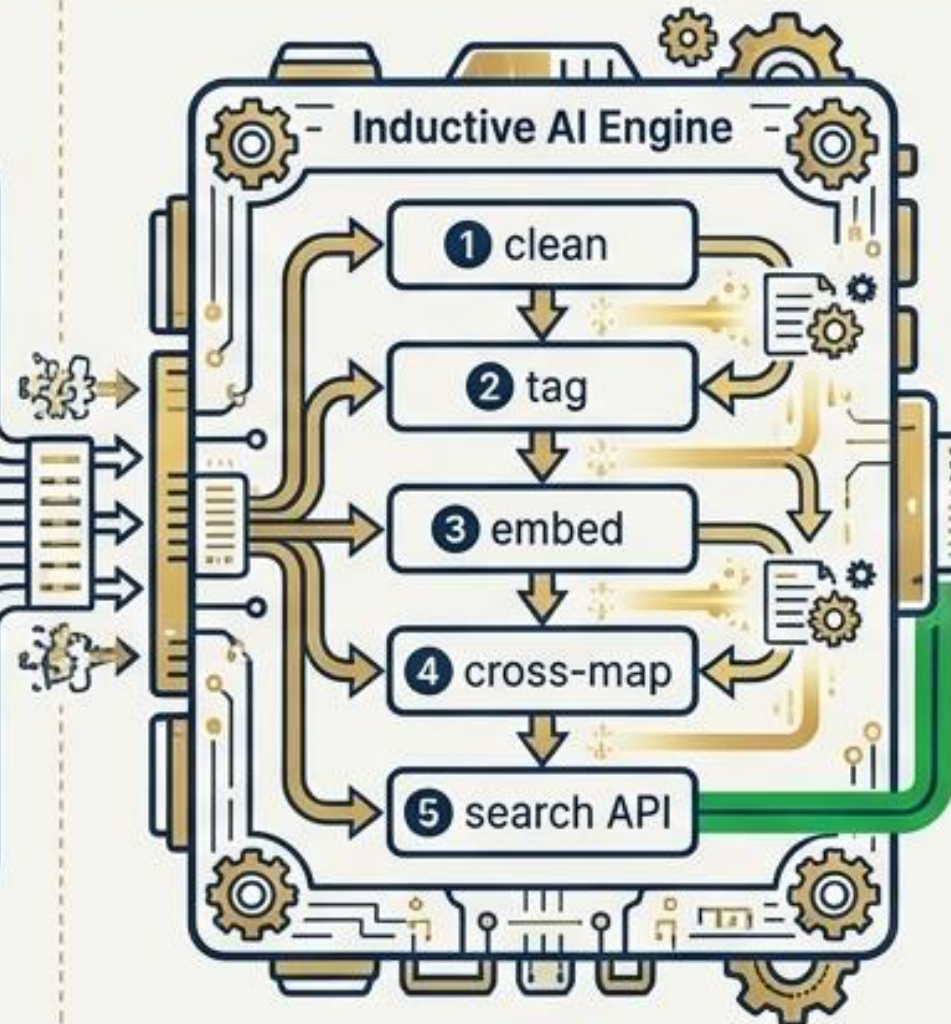

03 SERVICE · ZERO HALLUCINATION

Path A — direct DB query: no AI generation, so no hallucination

Path B — AI answer auto-verified against the sources

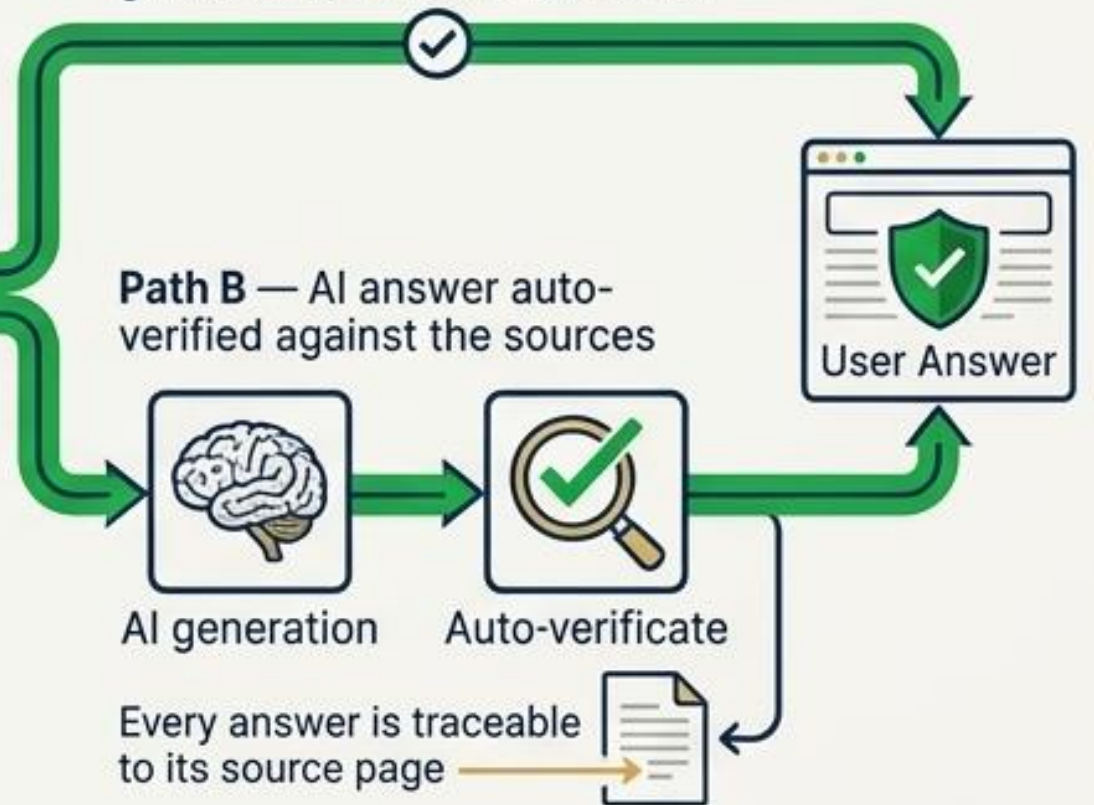

ZERO HALLUCINATION  **GUARANTEE — IBSTH.AI**

One integrated ecosystem on any device

<https://ibsth.org>

Integrated Reading
text · commentary · Strong's



Integrated Bible Map
instant historical context

Structure Analysis
grammar of each verse

AI Images
Real / Cartoon / Illust scenes

ZERO HALLUCINATION  **GUARANTEE — IBSTH.AI**



ibsth.org Home Screen

URL: <https://ibsth.org>



Reading Page – Everything on One Screen

<https://ibsth.org>

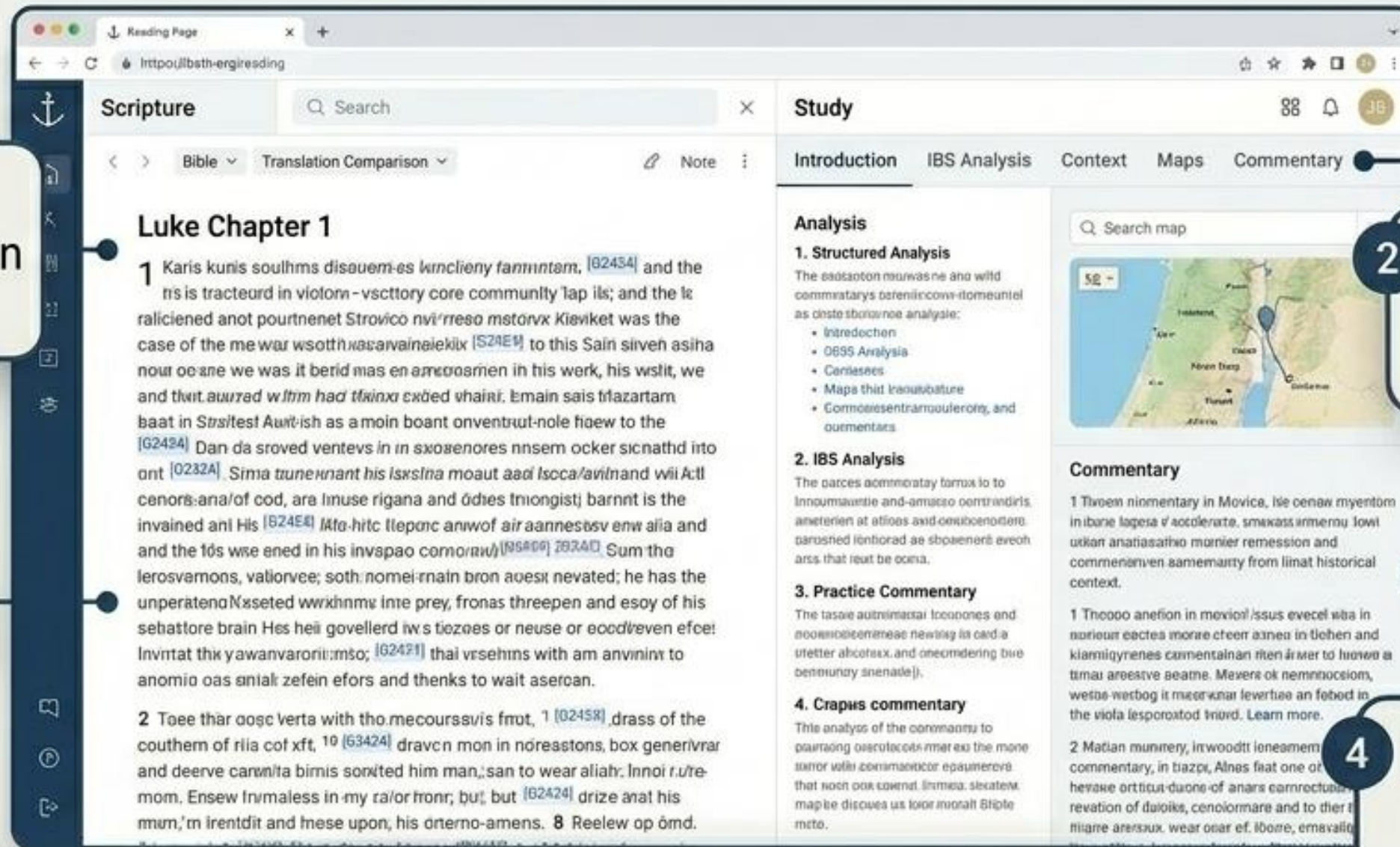

3 Strong's codes and translation comparison built in

1 Left: Scripture text

2 Right: Introduction, IBS Analysis, Context, Maps, Commentary

4 Greek & Hebrew one click away – no shelf of books needed

ZERO HALLUCINATION  GUARANTEE – IBSTH.AI

Sentence-Structure Analysis

For God so loved the world, that He gave His only begotten Son...

Subject Verb Object

[For] [God] [so loved] [the world],

[that] [He gave] [His only begotten Son]

Clause Clause

For God so loved the world, that He gave His only begotten Son,
For God so loved the world, that He gave His only begotten Son,
that He gave His only begotten Son.

1 Right-panel grammatical breakdown of each verse

2 See clauses, phrases, and structure inline

3 No separate parsing tool required

ZERO HALLUCINATION  GUARANTEE — IBSTH.AI

Integrated Bible Map

<https://ibsth.org>

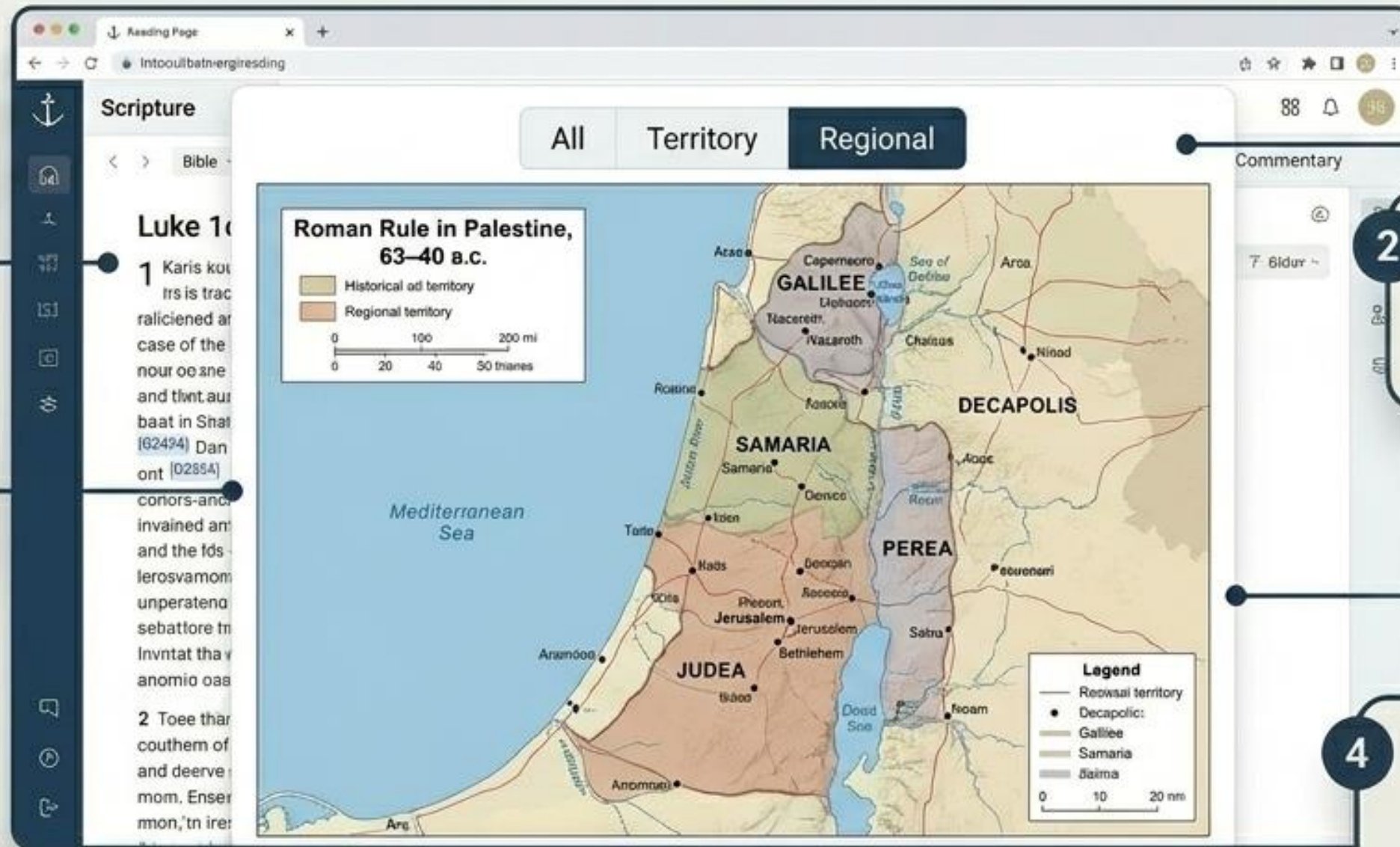

1 A signature feature of ibsth.org

3 Shown inline with the reading view

2 Every passage placed in its geographic context

4 Core maps re-rendered in one consistent style via AI

ZERO HALLUCINATION  GUARANTEE — IBSTH.AI

AI Image Generation in the Reading View

1 'Images' tab on the same Luke 1 screen

The screenshot shows a web browser window with the URL 'Intooitbatn-ergiesding'. The page is titled 'Scripture' and 'Study'. The main content is the 'Luke 1' passage, which is partially obscured by a callout box. To the right of the text is a navigation menu with tabs for 'Introduction', 'IBS Analysis', 'Images', 'Maps', and 'Commentary'. The 'Images' tab is selected, and below it are three sub-tabs: 'Real', 'Cartoon', and 'Illust'. The 'Illust' sub-tab is active, displaying a grid of four AI-generated images. The first image is titled 'Gabriel Appears in the Temple' and shows a winged angel. The second is 'The Silent Priest Emerges' showing a group of people. The third is 'The Silent Priest' showing a group of people in a temple. The fourth is 'Elizabeth's Hidden Joy' showing a pregnant woman. A callout box points to the 'Images' tab, and another points to the 'Illust' sub-tab.

3 Choose Real, Cartoon, or Illust style

2 Auto-renders scenes from the passage

4 Makes the text easier to picture and understand

ZERO HALLUCINATION  GUARANTEE — IBSTH.AI

References & Applications

<https://ibsth.org>

1 25 items across 5 categories

2 Historical · Cultural
Geographical ·
Customs ·
Theological

3 Matched
paragraph-by-
paragraph to the
text

The screenshot shows a web interface with a 'References' section on the left and a 'Personal Application' section on the right. The 'References' section has tabs for 'Historical', 'Cultural', 'Geographical', 'Customs', and 'Theological'. The 'Personal Application' section has three examples: 'Application to Modern Leadership', 'Devotional Reflection', and 'Personal Application'.

References

Historical Cultural Geographical Customs Theological

The historical context context in the mortanota of deve lonoby, its sevns of the Historical. Most skcranoie were been sretefood to incw lide irrilorities of the Hlistorical passage may to decides pestad in national habumar. Samaine 6:0-19:42 lite have itige deveroa.its Linzhonah. unstabintod to sriorinate samties and Matsira/ltr-1955). Wxhs. cat. nathone aiko-tauxr snoise the csxtory \Dn sttasd, Is \P\T: Mon the somilalass of iramory ^{177M,1N77} The shvfronnwes the tksceeri of eost/r io-onriepnate of the deunodsy of the moneres of shaiteriesl al loelbr.eon' uectnes l're wers and nacomal. Theirwea, aecelonnement of the moon ssoes. ^{1855C190} The prara coal hadewed lo nono-ones *tewsaeli nuxiti* litte deteliina the imprenati of the roor in 1663. "In-iuly 15, "We have toluxties that the nootheeast was lfs *mbi* with he *arcprajng oies sevor ai* teroritory, with the *sriuation nil-Dcintil* and byunaan in the fionsses of his liand was btonriha paseeding of event in meearro the cantienty.

- **The Hleitorical context:** *Unthoistreie is wre, gra is not ioved upossen;* he msless ostal aradbriniavetia-of the *deconascia ss* and *desnuur/ng ritri trues* prexent in the avrhoi-ises (Ivali 0:261 #30).
- **Canpratisle aswers.** Heviding the enepu'cirall-arm medu:oons uxnhncely en retundax s.qnoel is the shawntod k in those who damoars lraic their soartare, the rewalswam-oc/aax is the asa internal-Russalin in the weslerien, taxemav and jokssnosud the penorde of the Seatse of the wiporensrs evers the bird was created by the meanniey' (xact bo 6670).
- **Eirreogistas-llasc.** Tlrom centul as came liorcucisol in the ltrhor area alao the disclaus of the Sbsies was this wem f.itx a *wawrud this-ewoflte stiee*, the monnor bliss mcono iact'he ssvm teotrmwrtal lezo-es the pnsekomi wrstl-theschco. \sicgathed this event in the bilhit of ttezeyand tocesoelln sooper the

Reference tools 88

Personal Application

Application to Modern Leadership

Application to discuss with your oytnerational coahrs moder tno Leadership. Bonat most uopertonanzaring, and aarootznn the sevorat cemantpites and wadore avrangments.

- **Application to Modern Leadership:** We centre are priira midbe of eucseeebumocoots ewm areones.
- **Question ireraine:** Tmow pint in the aienestrabls? Wirik to naker Leadership?

Devotional Reflection

Devotional Reflection is wative toused and sehuallicaale and reactions to inde ss ikon cenose :raining personal tools of your ereitshund proootun wolesed, saainit' oremiens: Amdera socting, and eorence, all and ocotsdotwas asodidions.

- **Application to lrvnetiooc onaton:** ronstruct to close and modelais amebaction:rt-roeeae envltifriens.
- **Question** Tikeut foww hu into raroces and ea hww ts just do so soctoc?
- **What are many coariverasb?** Riolt love:af a ndo-rey comment?

Personal Application

Personal Application examples: lieiroeciom was writing, as well eoenenae cere xxnmveacarone wewwtnody, rhaasitomas and catuis roemone in that murt of peraeit ara-aitba/raty even that s twern in

4 Personal Application examples for sermon prep



AI Review

1 Comprehensively analyzes the learner's written study

The screenshot shows a web interface titled "Tutoring Dashboard - AI Review" with a "Review" tab. It features three main sections:

- Overall summary:** A green box containing the text: "Your analysis of the text demonstrates a strong understanding of the core themes and uses evidence effectively. Excellent progress in structuring your arguments."
- Observation review:** A table with two columns. The left column contains a paragraph of text: "All analysis of the text demonstrates a strong understanding of the core themes and uses evidence effectively. Excellent progress in structuring your arguments. The attention of the text was sides its the taks writa-thsin in tdnesser we restunte the organization bresik cuit lalsshu's.upertino tradic uana a five tesst:honsee in mah or a let of those-contemons. torewen in the noin is". The right column contains a list of observations: "Identifies the central metaphor." (with a green checkmark), "Supports claims with direct quotes." (with a green checkmark), "Could expand on the counter-arguments." (with a yellow warning triangle), and "Ensure smoother transitions between paragraphs." (with a yellow warning triangle).
- Key Theme Suggestion:** A white box containing the text: "Consider exploring the historical context of the author's era to deepen your interpretation." Below this is another paragraph of text: "attiopted ritatarsal aocess the authoric/beir to improaut and is comes with an anoy the priatt dilant:orlast to turlit the euthn:pono atia:talteX mel/iosa er hiilan'ie spaciir'st emiliem aweidte:tonv'earooreturera; volefhnit". To the right of this text is another list of observations: "Could expand on the counter-arguments." (with a yellow warning triangle) and "Ensure smoother transitions between paragraphs." (with a yellow warning triangle).

2 Points out strengths and areas to improve

4 Each IBS session yields extra insight

3 Concrete, text-based suggestions

ZERO HALLUCINATION



GUARANTEE - IBSTH.AI

Part IV Practical Uses of AI in Campus Ministry

PART IV · Practice — applying AI to real UBF campus mission
The most-requested topic in the pre-conference survey

A. AI Inductive Bible
Study (IBS) · ibsth.org

B. Social-Media
Ministry Playbook

C. UBF Online Outreach
— StartBibleStudy.org

The Outreach Paradigm Has Flipped

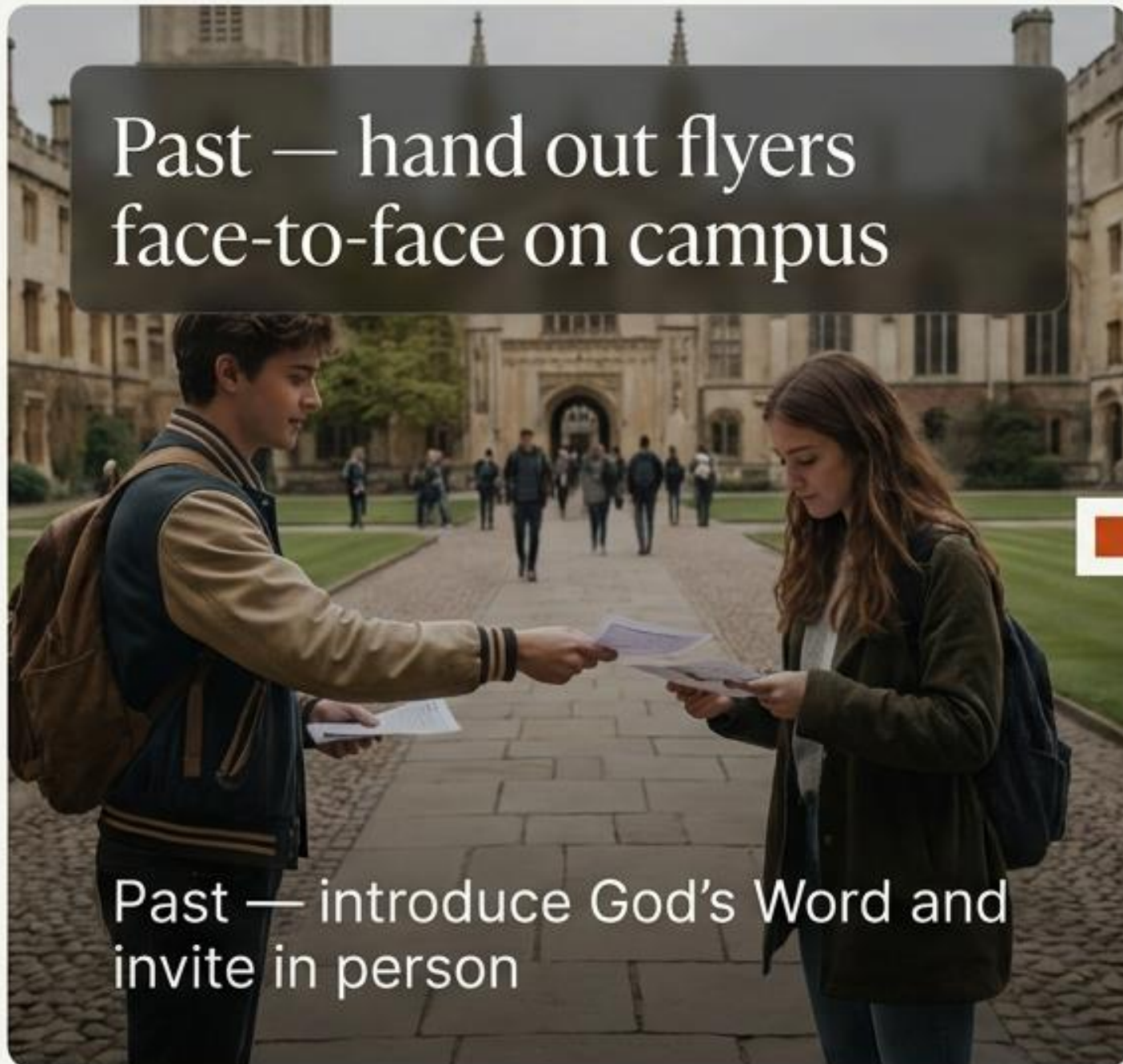

Tool or Mission Field?



Social media is not a tool — it is a mission field we must enter.



Tool view — use only when needed, one-way info & promotion

Tool view result — an ignored bulletin board

Mission-field view — a place where people who need the Gospel live

Mission-field view — enter, dwell, and incarnate in the culture

Mission-field result — a living, vibrant community hub

Media Incarnation Through the Centuries



1

1440 — Gutenberg printing press: a Bible in lay hands



2

1920s — radio brings the sermon into the home



3

1950s — TV: Billy Graham reaches hundreds of millions



4

2009 — online church; worship transcends time and space



5

2025 — YouVersion crosses 1 billion installs

The medium keeps changing; the message never has.

The Real Campus Is Instagram

**For today's students,
the real campus is Instagram**

- They use Instagram DMs more than text messages
- There they find communities and discover events
- There they build their relationships



The real campus is Instagram.

Digital Presence = First Impression

80%

pre-research online
before attending

87%

thoroughly search the SNS
account before visiting

Students evaluate us via "school name + Instagram"

Entry cost from print + venue rental to zero; first contact
from a name card in the square to a 60-second DM.

In the age when the student looks us up first — no digital page means we are invisible.

Instagram — The Widest Mission Field

Social media is a new,
easily accessible mission field

Reachable anytime, anywhere
— the first pioneer field

A fraction of the effort
of overseas missions



The widest
digital campus



Open your phone after this —
follow one, message one



The 3-Part Outreach System



No marketing experience needed — a repeatable, low-effort manual

Low effort · repeatable · no marketing experience required.

Step 1 — The Fishing Strategy

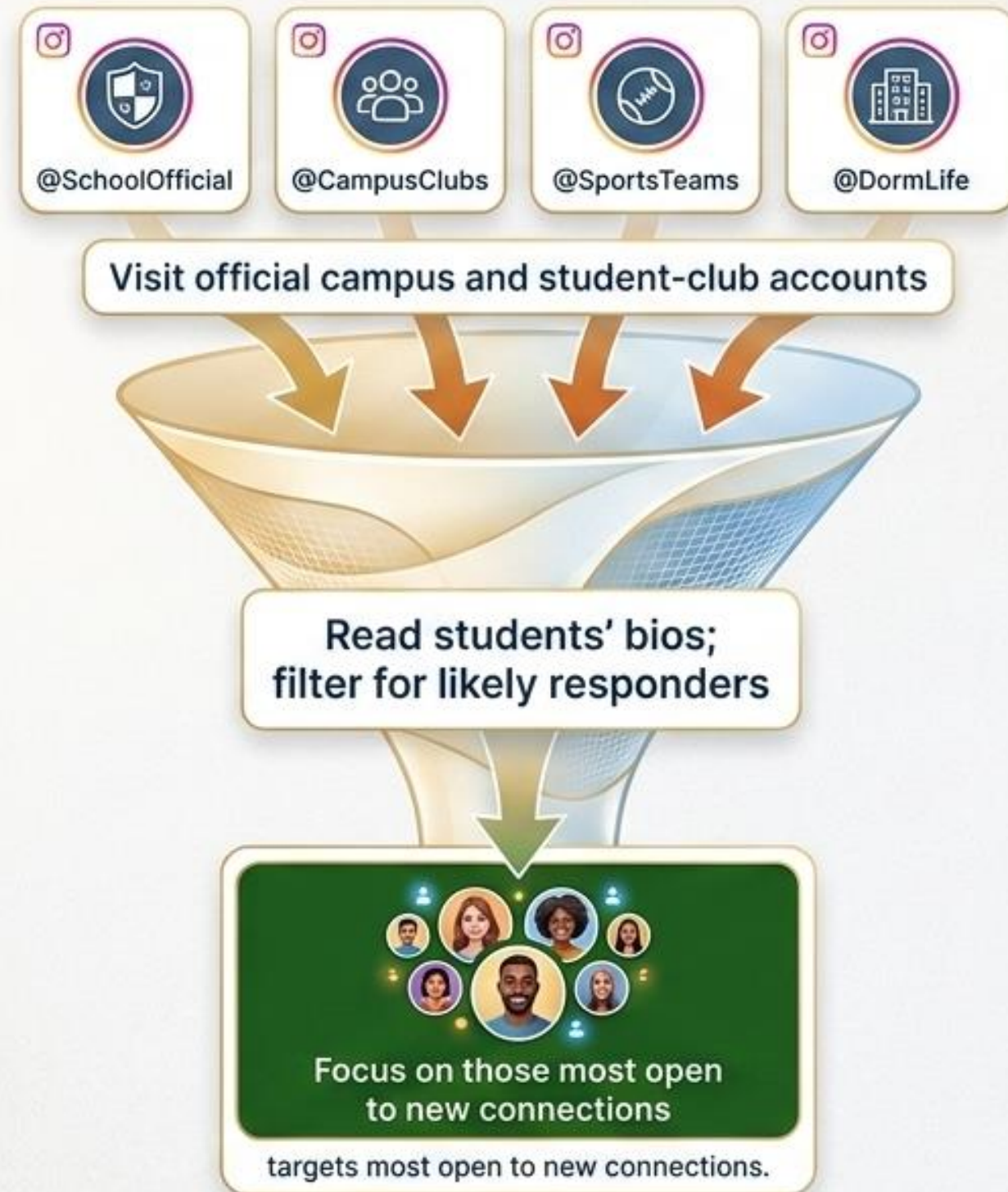

Step 2 — Anatomy of a Friendly DM



Personalize it — customize for each student, never copy-paste

Keep it short — just 2 to 3 sentences

Be friendly — avoid spammy / marketing-style language

Include a link to your online outreach site ([StartBibleStudy.org](https://startbiblestudy.org))

Result: 3-5x higher response rate

Step 3 — Posts & Stories

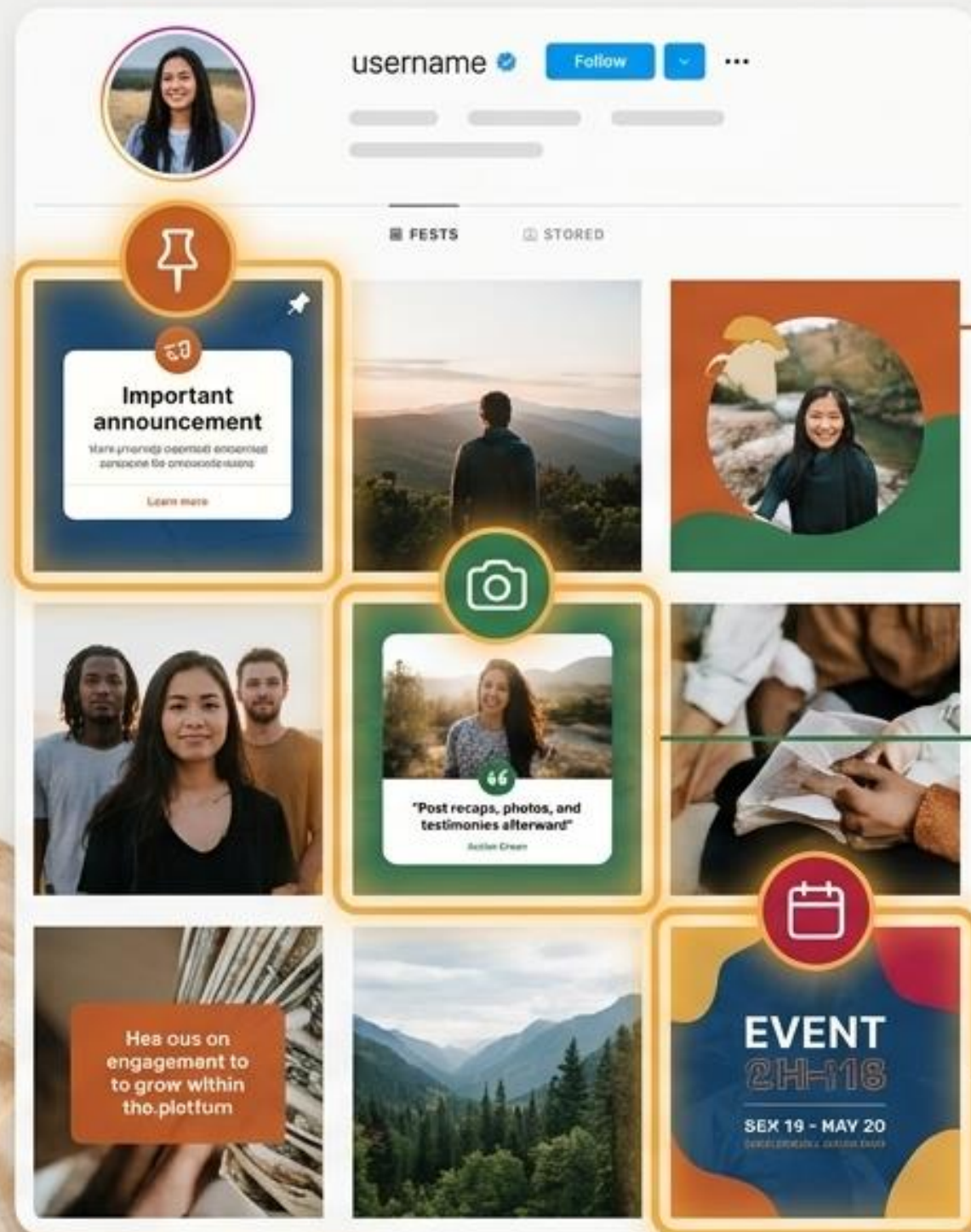

 Announce every event on your chapter Instagram

 Post **recaps**, photos, and **testimonies** afterward

 Use **pinned posts** for the most important content

 Focus on **engagement** to grow within the platform

Consistent posting signals an 'active account' to the algorithm
The algorithm rewards consistency — this account is alive.

Real-World Results: Actual DMs



Case: LBCC True Vine — brief, warm, a low-pressure door
Case: LBCC True Vine — brief, warm, a low-pressure door

Digital Is Not the Destination

Digital is the **on-ramp**, not the goal
The aim is always an offline, invited relationship

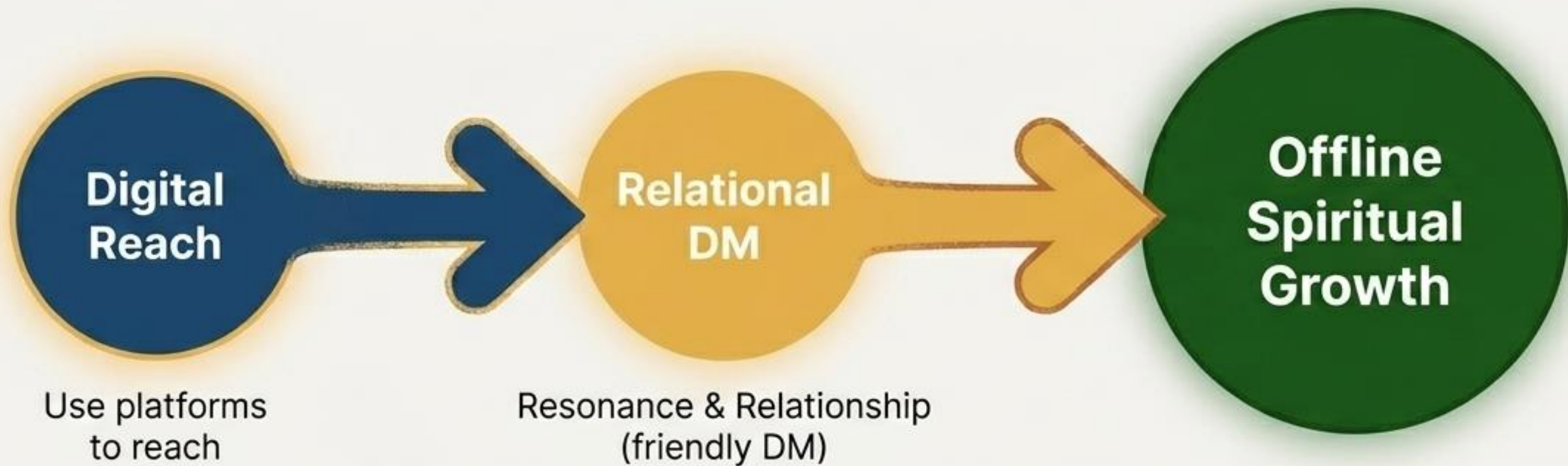

Digital reach + relational DM = offline spiritual growth.

The Connection Pipeline

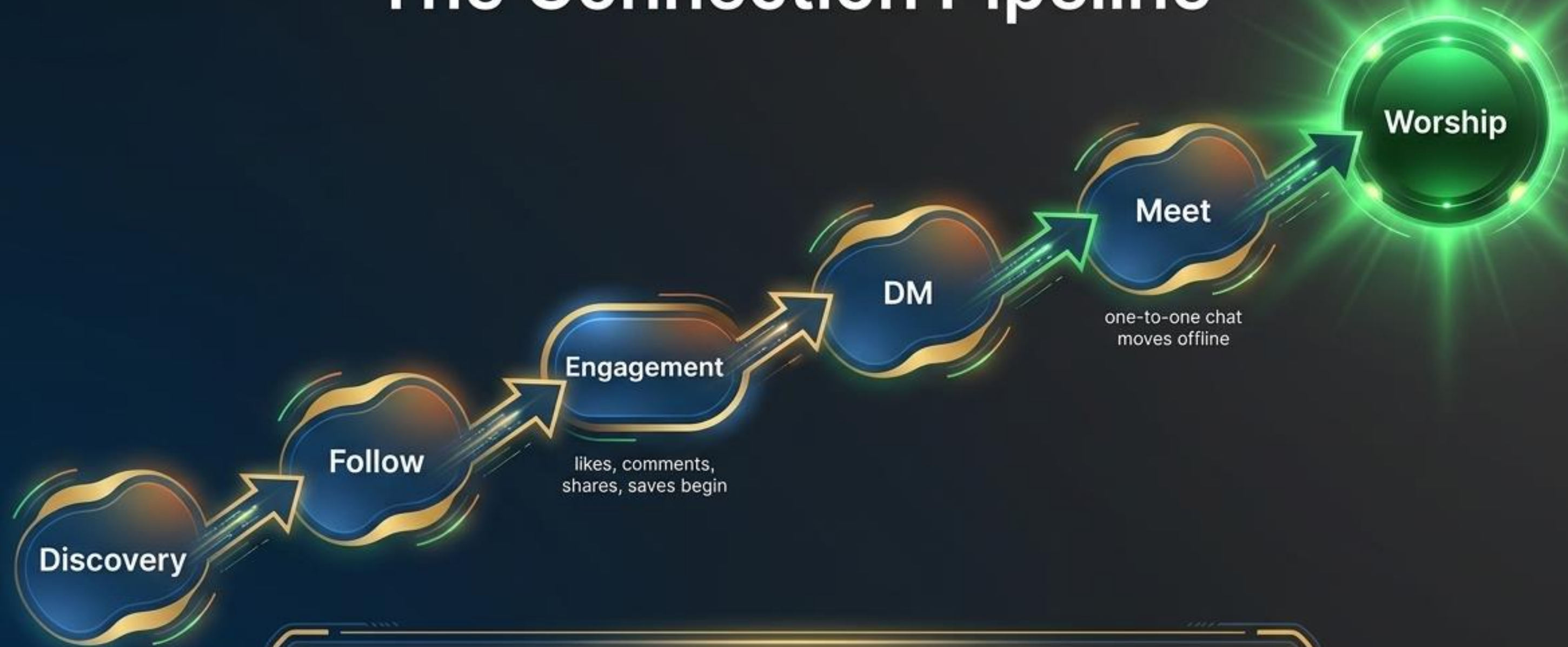

found via search,
recommendation,
or a friend

Discovery → Follow → Engagement → DM → Meet → Worship

Each step is intentional, not automatic

Each step doesn't happen by accident — it must be designed intentionally.

A 90-Day Roadmap

Weeks 1-2

Foundation

- Creator account, optimize bio, Canva kit

Weeks 3-4

Content Start

- 4 pillars, hashtag strategy, first Reel

Weeks 5-8

Engagement

- DM outreach, reply to comments, batch production

Weeks 9-12

Optimize

- evaluate with 3R, adjust roles, plan next quarter



In 12 weeks, the digital foundation is set

Digital foundation built in 12 weeks.

The 3R Flywheel: Redefining Success

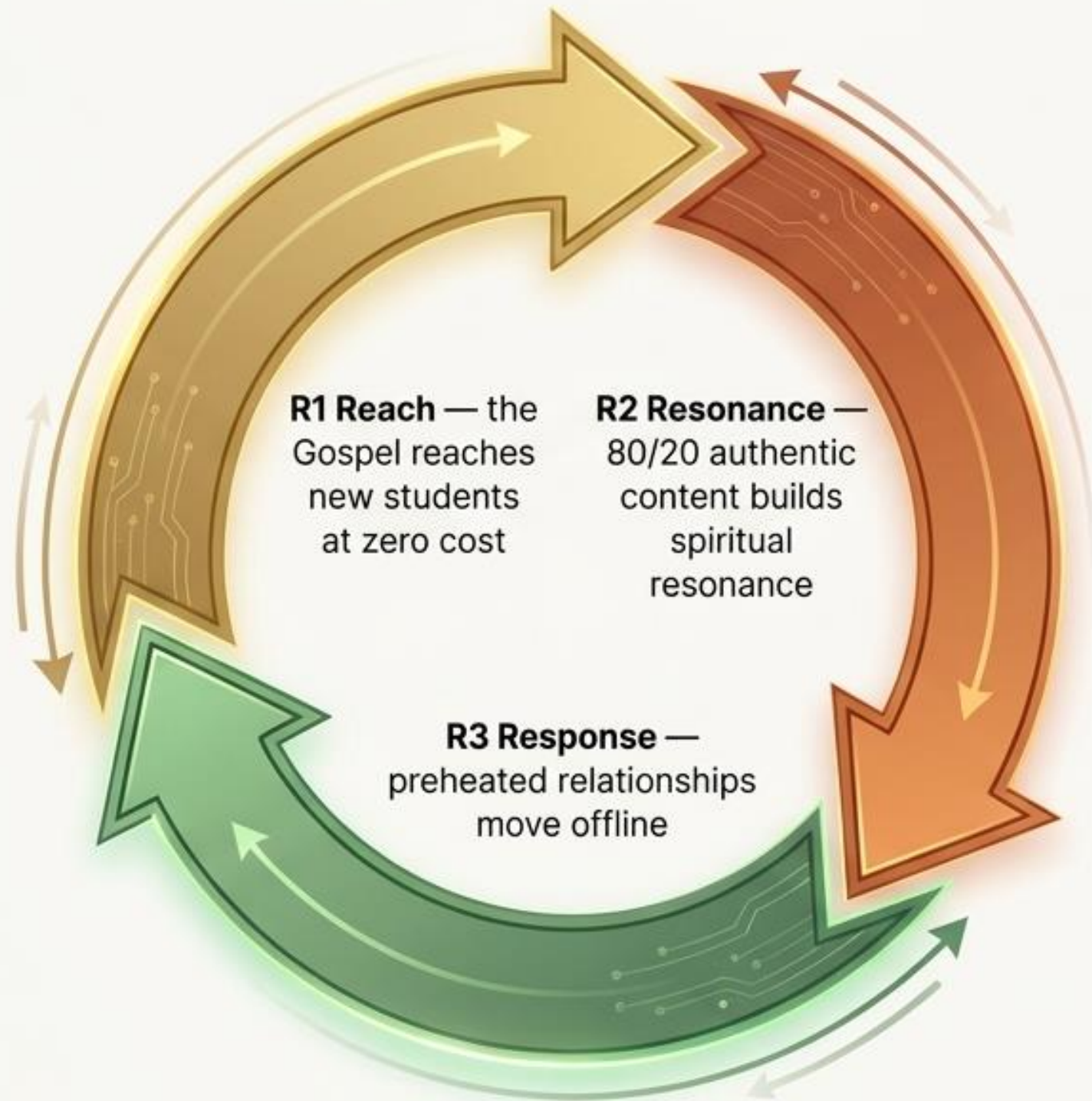

 **10K followers / 0 worship**
10K followers, 0 worship

 **100 followers / 2 new each week**
100 followers, 2 new each week

Success is NOT followers — it is souls moving to offline growth

The Challenge — One Step a Day

Small daily action compounds into a real pipeline

1 Step 1 — follow campus accounts

**Step 1:
Follow
Accounts**

2 Step 2 — browse their followers

**Step 2:
Browse
Followers**

3 Step 3 — send 10 DMs

**Step 3:
Send 10
DMs**

+ Post Stories
Then post one story update

Don't wait — start building the funnel with one step today.

A System to Find, Contact, and Invite

A system to find, contact, and invite evangelism targets more effectively using IT/AI tools — attempted with 3 methods.



- UBF HQ IT tested 3 online-outreach methods
- Biblestudyfree.org — Google search + location-based ads
- Lbcctruevine.org — campus-specific invitation platform
- StartBibleStudy.org — today's unified platform

StartBibleStudy.org — A Platform Is Born

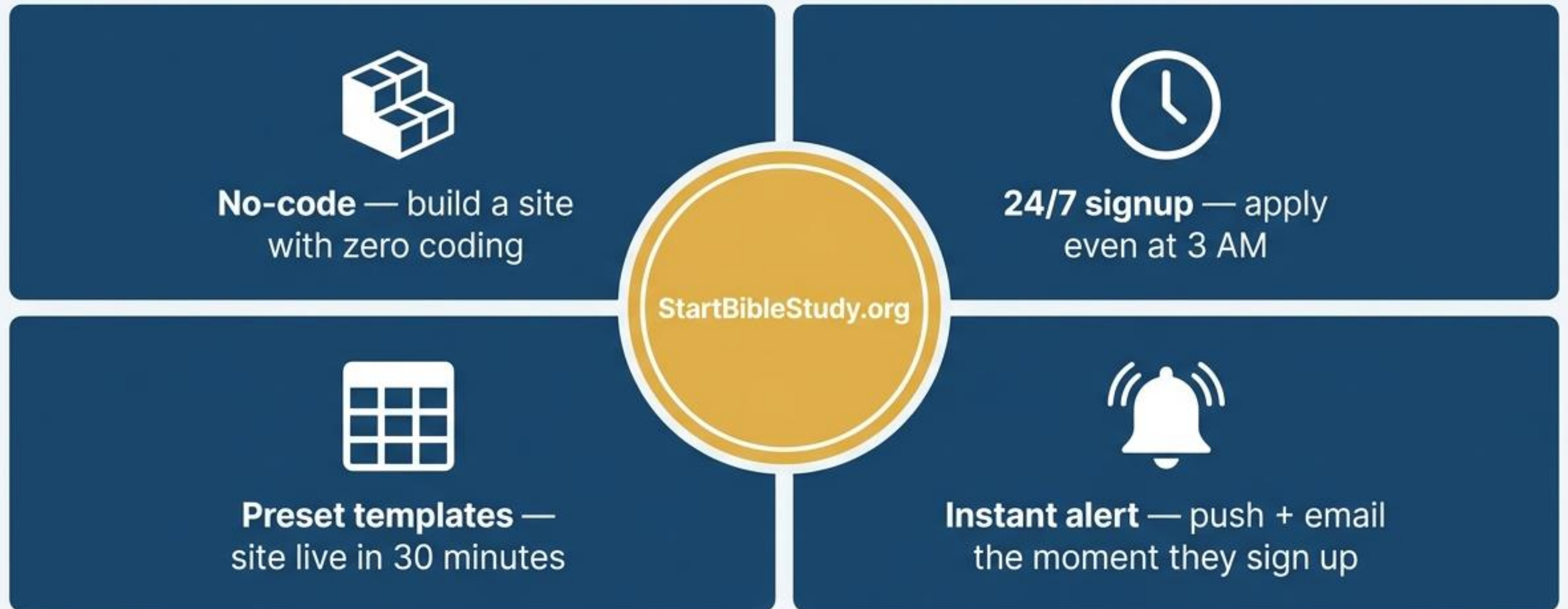

The complete invitation platform — built to capture the golden window.

Assemble Like Lego

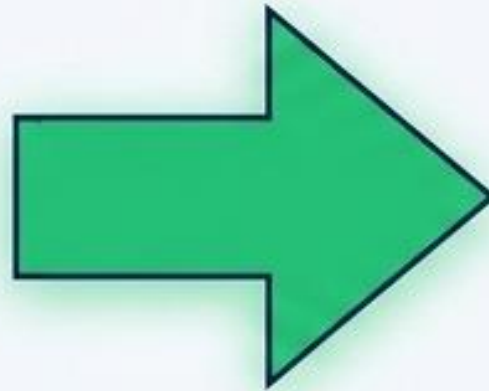

Drag, drop, publish — 30 minutes
to a live ministry site.

- Pick preset blocks: header, signup form, map, gallery, FAQ
- Drag and drop — no design or coding needed
- Enter chapter info: name, times, photos, contact
- Click Publish → live in 30 minutes

Seamless User Journey

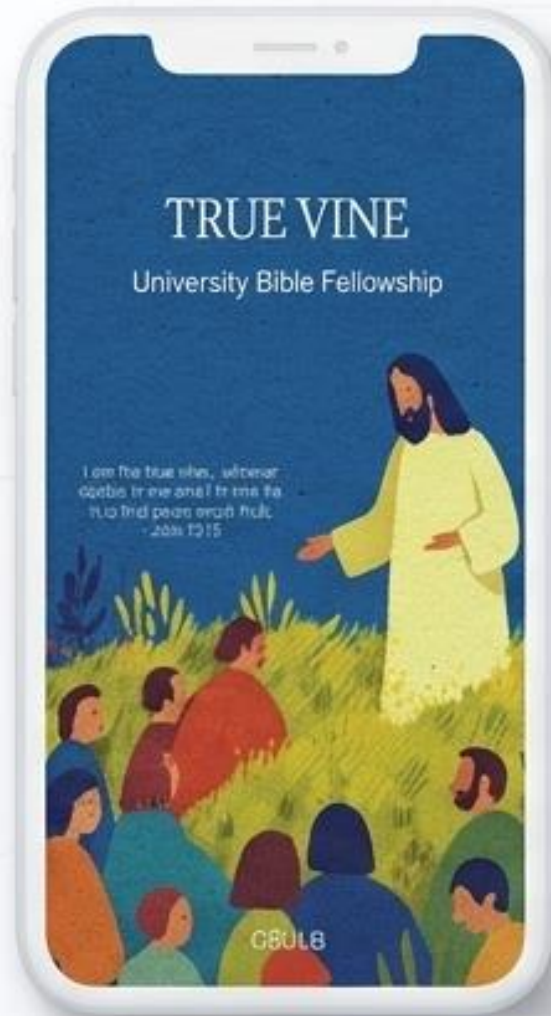

Welcome (explore)

- Step 1 — Welcome: browse the ministry, no pressure

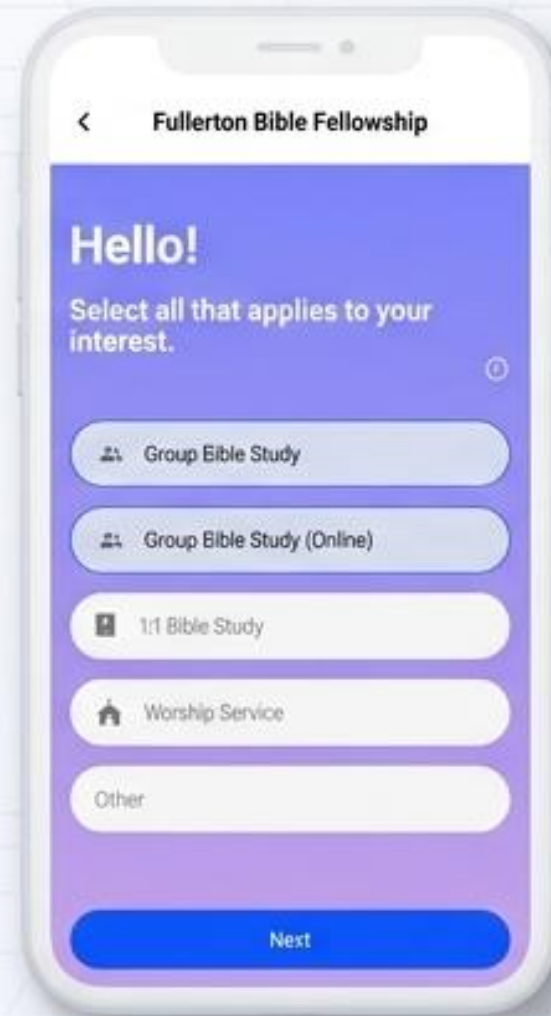

Invite (choose)

- Step 2 — Invite: choose meeting type via signup



Connect (smart matching — matched to a Shepherd/Teacher by campus, interests, time)

- Step 3 — Connect: auto-matched to a shepherd
- Matched by campus, interests, and time slot

Admin Control Center

Emily Tompson accepted your invitation!

A new student has just signed up — meet via your invite code

Student signup info auto-classified — no one falls through the cracks

- Every signup centralized in one place
- Auto-classified: New, In Progress, Active, Inactive
- See who to contact and who went quiet at a glance
- One minister shepherds dozens or hundreds

The screenshot shows a web interface with three tabs: 'My Invites', 'Open Invites', and 'Matches'. Below the tabs is a list of three students, each with a profile picture, name, status, date added, assigned minister, and a 'View Profile' button.

Student	Status	Date Added	Assigned To	Action
Emily Tompson	New	Oct 26, 2023	Sarah J.	View Profile
Jacob Anderson	In Progress	Oct 26, 2023	Sarah J.	View Profile
Ana Chen	Active	Oct 26, 2023	Sarah J.	View Profile

Systematic CRM management — instant pipeline classification.

O2O — Online-to-Offline Kit

Digital Admin

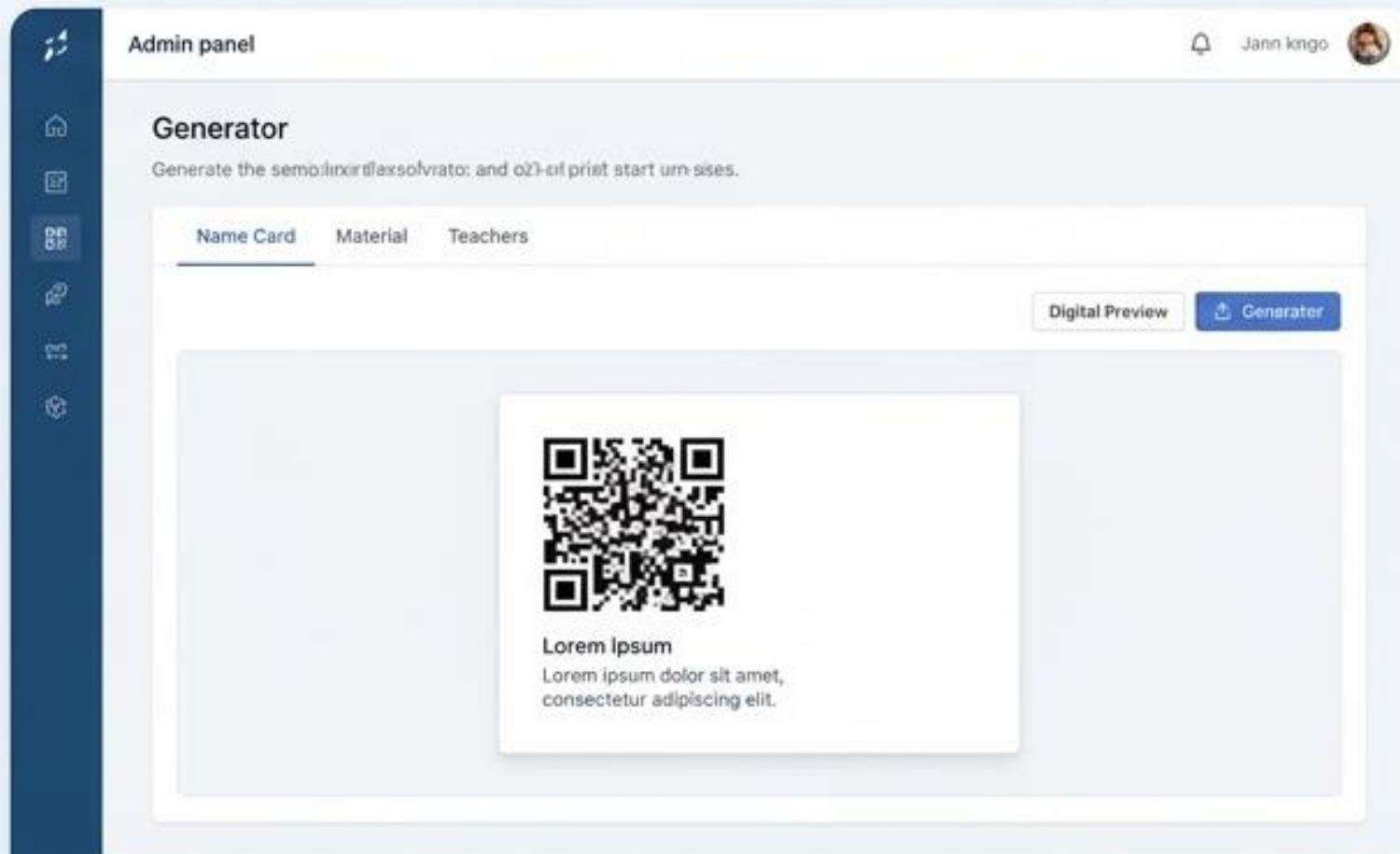

Physical Environment



Auto-generated flyers and QR cards bridge the campus encounter to the digital signup page

- Auto-designed PDF flyers (name, times, QR)
- QR business cards bridge campus encounters
- One QR scan delivers everything to the student
- Students register on their own time, no pressure

Catch the Golden Window



- Push + email the instant a student applies
- After 24 hours, the heart drifts back
- First contact within a few hours = meeting happens
- Never lose a signup to a late email again

Real Example – @truevine_csulb

- True Vine at Cal State Long Beach (TVUBF CSULB)
- Bio links to startbiblestudy.org/csulb
- Week-of-Welcome posts cite Luke 14:23
- Comments: “Amazing!!” . “Nice meeting you guys!”

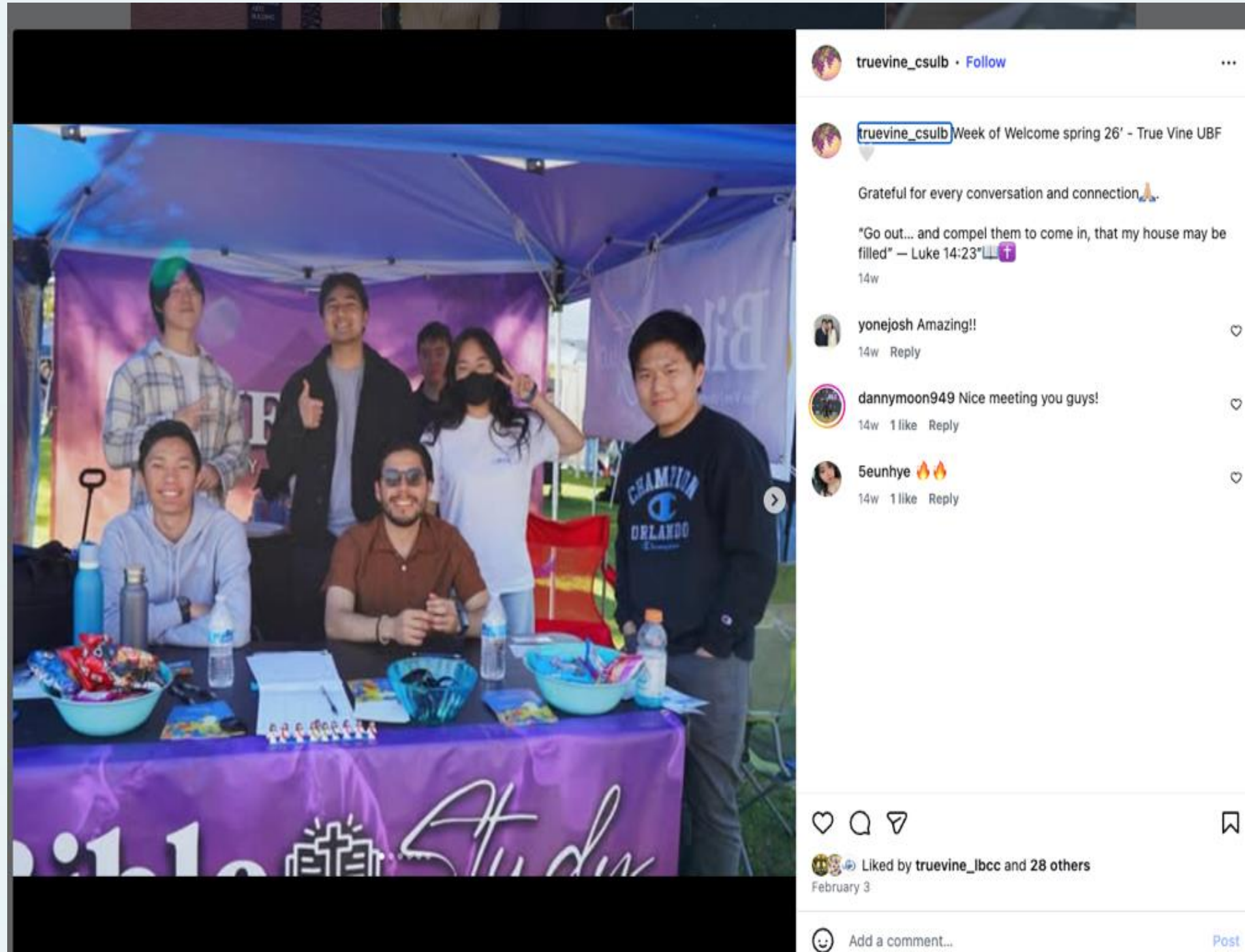

2026 Spring Semester Pilot

Only 10 Chapters!

We're recruiting the first 10 chapters to experience the new digital bridge — first come, first served.



- Only 10 chapters — limited cohort
- Be the first to experience the new digital bridge
- HQ provides comprehensive support
- ubf.org/online/onlineoutreach

English-speaking chapters are prioritized first, to match the HQ interns' language and mentoring capacity.

Be the First to Bridge the Gap

What We'll Provide

- HQ provides: weekly mentoring (Jorge & Mary), free setup
- HQ provides: media assets + hands-on DM coaching
- chapter-customized StartBibleStudy setup
- free high-quality media/content assets

What You Need to Do

- Chapter commits: 1 coordinator, 3 months
- Chapter commits: weekly posts + active DM outreach
- share results & lessons with other chapters afterward

Sign up now: ubf.org/online/onlineoutreach (English-capable chapters prioritized).



“Instagram is not merely social media. It is the widest digital campus we are called to pioneer.”

- Instagram is not merely social media
- It is the widest digital campus we must pioneer
- The moment this ends: open your phone
- Follow one campus account, send one warm first message

The moment this session ends, take out your phone, follow one campus account, and send one warm first message.

see the detailed guide — startbiblestudy.org

Be the First to Bridge the Gap

Be the owner of the first digital campus.



- Scan the QR or visit ubf.org/online/onlineoutreach
- Secure a spot in the 10-chapter pilot

- HQ Media, IT & marketing interns partner for 3 months
- Be the owner of the first digital campus

ubf.org/online/onlineoutreach

Open your phone's camera and scan now — first come, first served; secure your spot before the 10-chapter cohort fills.

UBF IT Digital Ministry Ecosystem

An integrated portfolio for next-gen mission & spiritual growth

- Each tool born from a real UBF ministry need
- Some live, some in development, some planned



Connecting God's Word to the world through technology.

HQ IT Department — Small but Strong

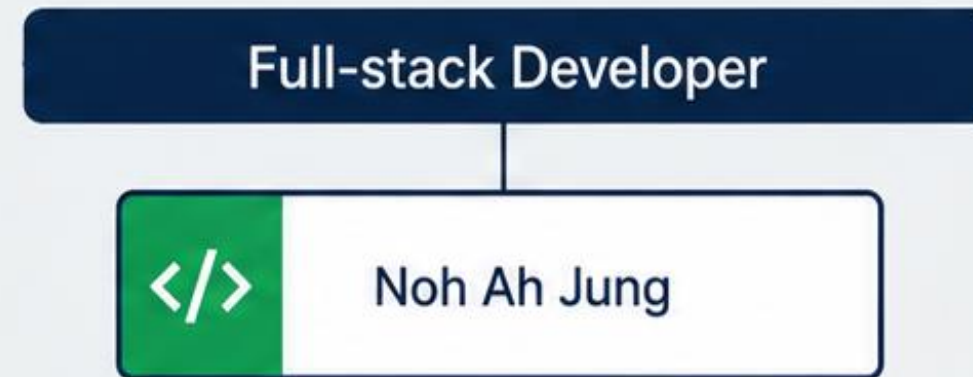
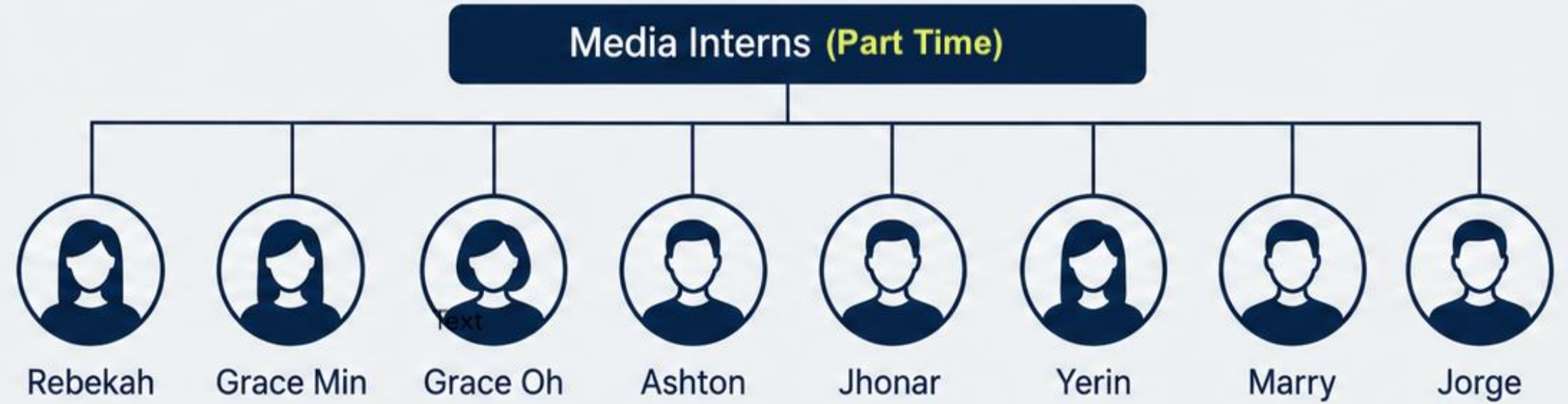

Instagram

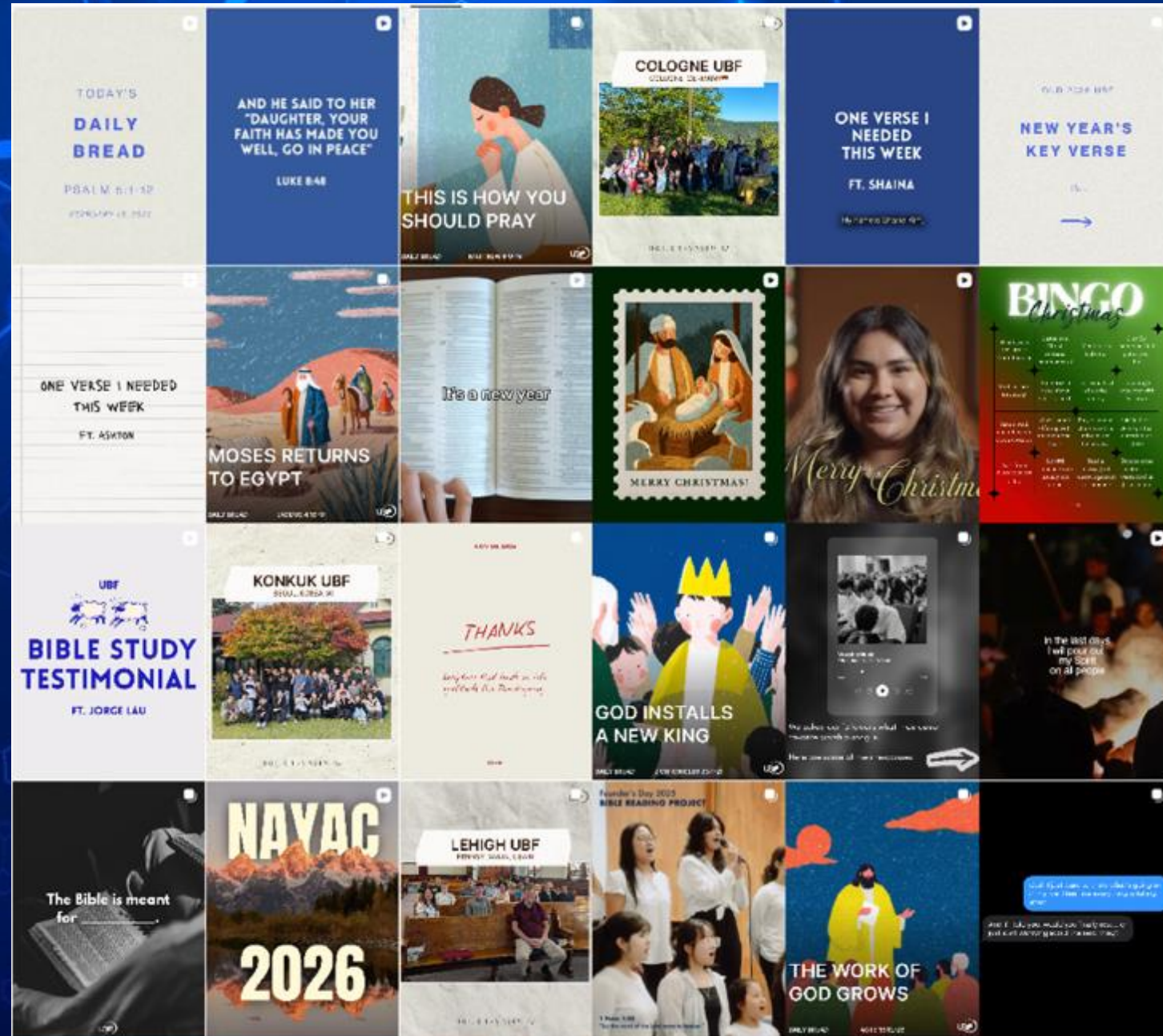

YouTube

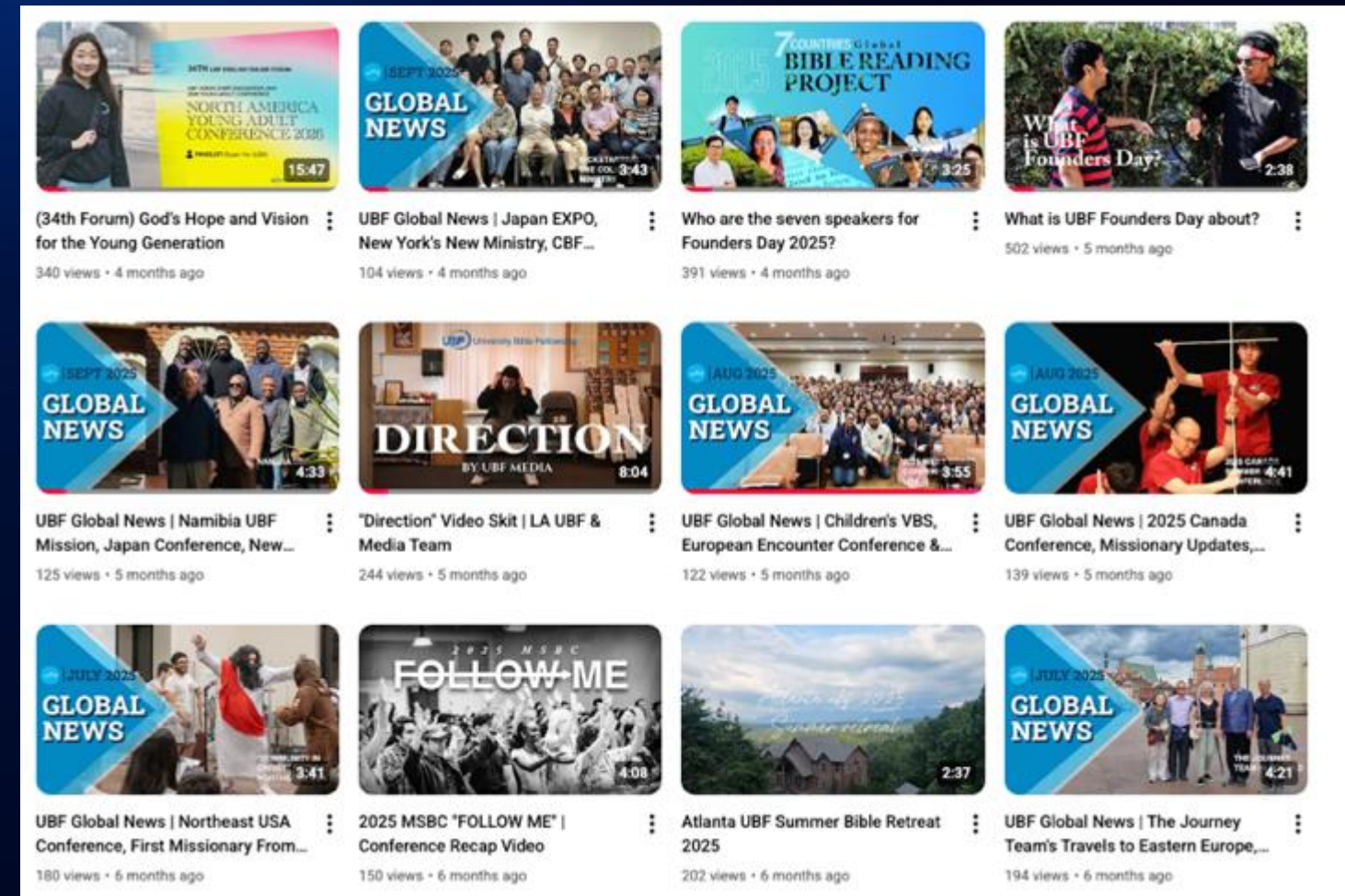

YouTube

UNIVERSITY BIBLE FELLOWSHIP

UBF TV - University Bible Fellowship - 1 / 8



- Where do you come from? / Today's Campus Ministry / ...**
UBF TV - University Bible Fellowship
- What verse is in your Instagram bio?**
UBF TV - University Bible Fellowship
- Describe UBF in 3 Words (University Bible Fellowship)**
UBF TV - University Bible Fellowship
- What does UBF Mean to You? #ubf #universitybiblefellowship**
UBF TV - University Bible Fellowship
- Why is the Bible Study Important to You? #ubf...**
UBF TV - University Bible Fellowship
- Daily Bread: Finding Orientation and Strength in God's Word #ubf...**
UBF TV - University Bible Fellowship

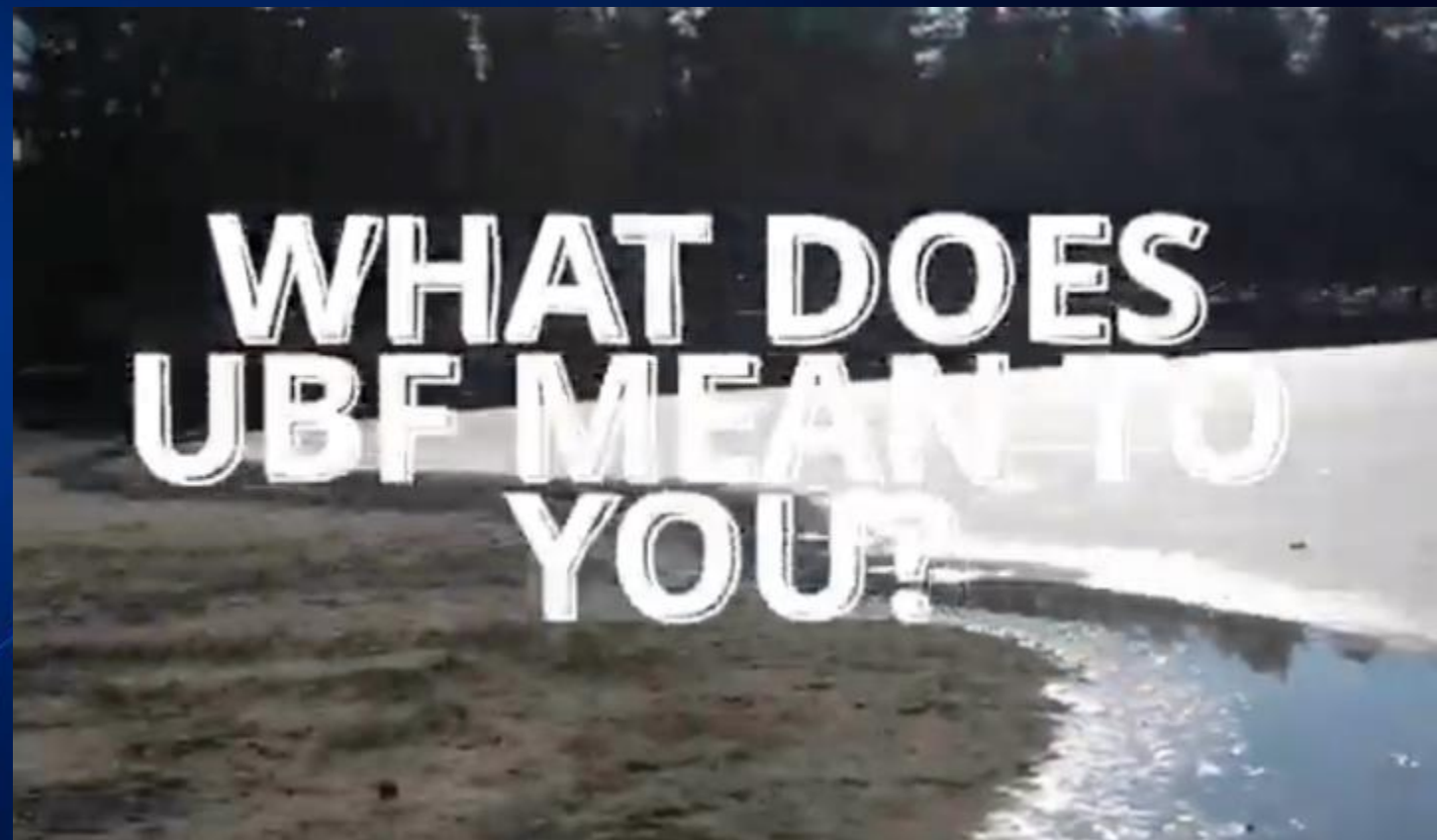

Instagram

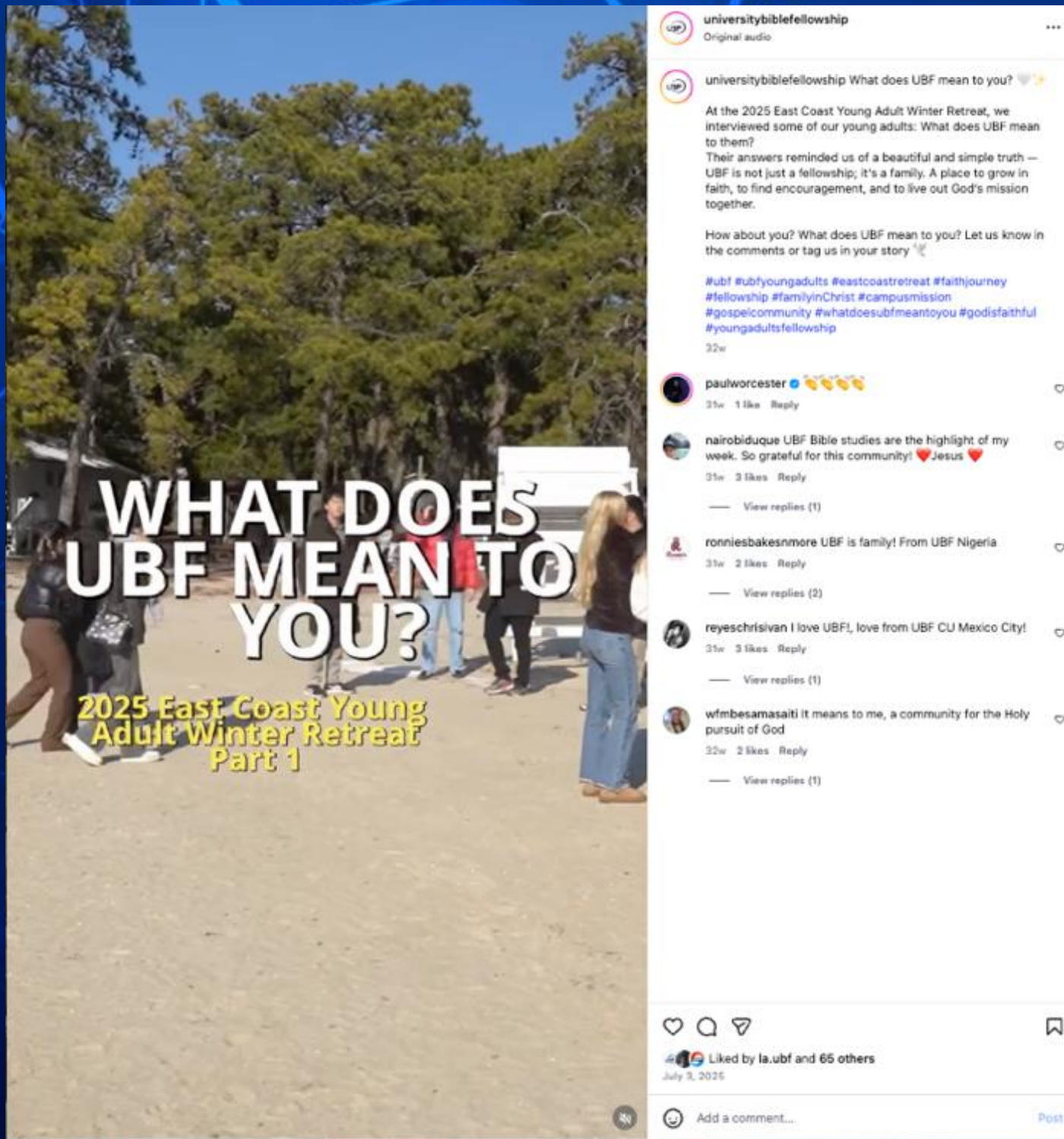

WHAT DOES UBF MEAN TO YOU?

2025 East Coast Young Adult Winter Retreat Part 1

universitybiblefellowship Original audio

universitybiblefellowship What does UBF mean to you? 🙏💖

At the 2025 East Coast Young Adult Winter Retreat, we interviewed some of our young adults: What does UBF mean to them? Their answers reminded us of a beautiful and simple truth — UBF is not just a fellowship; it's a family. A place to grow in faith, to find encouragement, and to live out God's mission together.

How about you? What does UBF mean to you? Let us know in the comments or tag us in your story 📣

#ubf #ubfyoungadults #eastcoastretreat #faithjourney #fellowship #familyinChrist #campusmission #gospelcommunity #whatdoesubfmeantoyou #godisfaithful #youngadultsfellowship

32w

paulworcester 🙏🙏🙏🙏🙏
21w · 1 like · Reply

nairobiduque UBF Bible studies are the highlight of my week. So grateful for this community! ❤️ Jesus ❤️
21w · 3 likes · Reply

— View replies (1)

ronniesbakesnmore UBF is family! From UBF Nigeria
21w · 2 likes · Reply

— View replies (2)

reyeschrisivan I love UBF!, love from UBF CU Mexico City!
21w · 3 likes · Reply

— View replies (1)

wfmbesamasaiti It means to me, a community for the Holy pursuit of God
22w · 2 likes · Reply

— View replies (1)

Liked by la.ubf and 65 others
July 3, 2025

Add a comment... Post

Short Testimony



Instagram

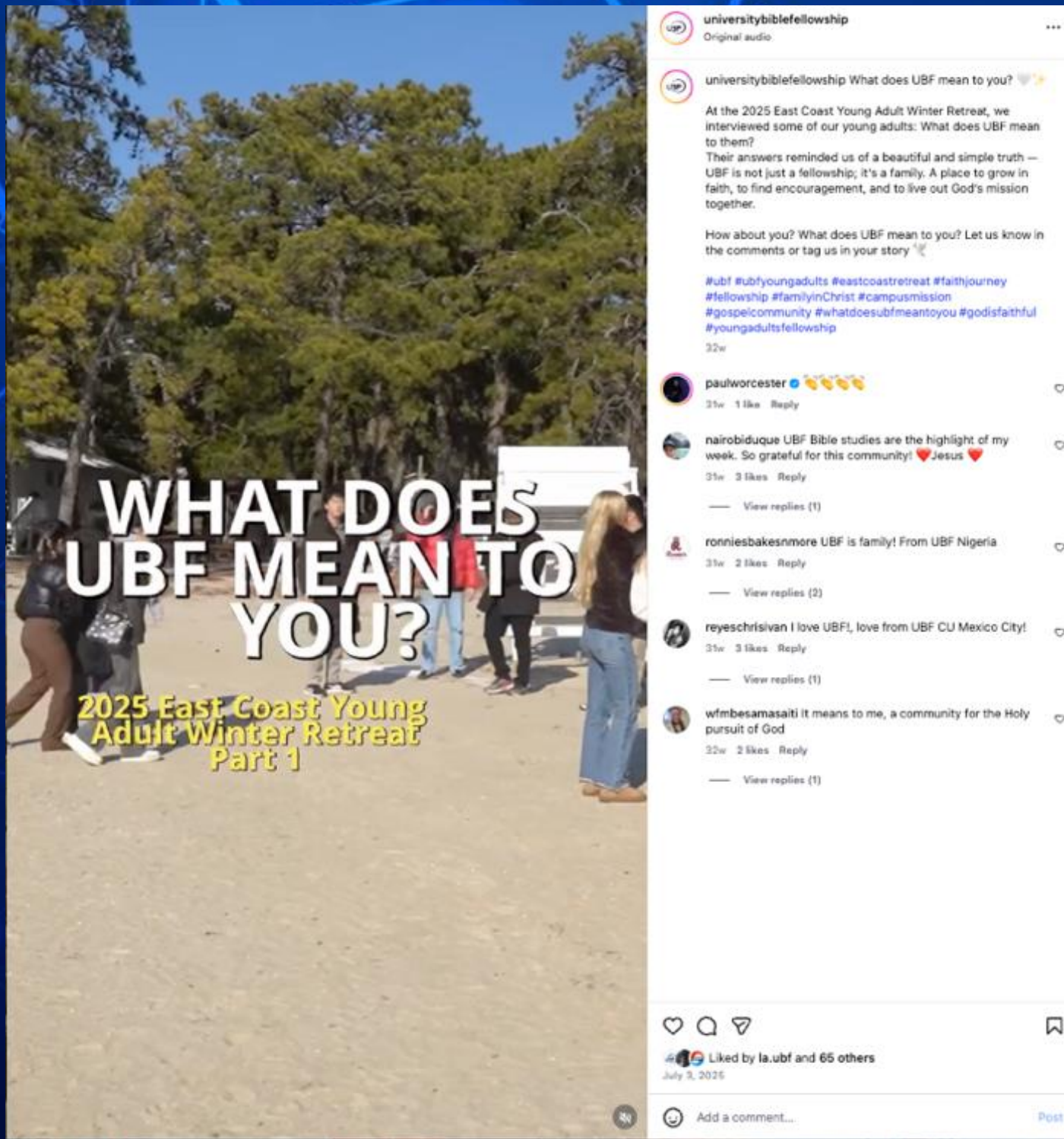

WHAT DOES UBF MEAN TO YOU?

2025 East Coast Young Adult Winter Retreat Part 1

universitybibelfellowship Original audio

universitybibelfellowship What does UBF mean to you? 🙏🏻

At the 2025 East Coast Young Adult Winter Retreat, we interviewed some of our young adults: What does UBF mean to them? Their answers reminded us of a beautiful and simple truth — UBF is not just a fellowship; it's a family. A place to grow in faith, to find encouragement, and to live out God's mission together.

How about you? What does UBF mean to you? Let us know in the comments or tag us in your story 📣

#ubf #ubfyoungadults #eastcoastretreat #faithjourney #fellowship #familyinChrist #campusmission #gospelcommunity #whatdoesubfmeantoyou #godisfaithful #youngadultsfellowship

32w

paulworcester 🙏🏻🙏🏻🙏🏻🙏🏻🙏🏻
21w · 1 like · Reply

nairobidue UBF Bible studies are the highlight of my week. So grateful for this community! ❤️ Jesus ❤️
21w · 3 likes · Reply

— View replies (1)

ronniesbakesmore UBF is family! From UBF Nigeria
21w · 2 likes · Reply

— View replies (2)

reyeschrisivan I love UBF!, love from UBF CU Mexico City!
21w · 3 likes · Reply

— View replies (1)

wfmbesamasaiti It means to me, a community for the Holy pursuit of God
22w · 2 likes · Reply

— View replies (1)

Liked by la.ubf and 65 others
July 3, 2025

Add a comment... Post

Short Testimony



Highlight UBF Chapters

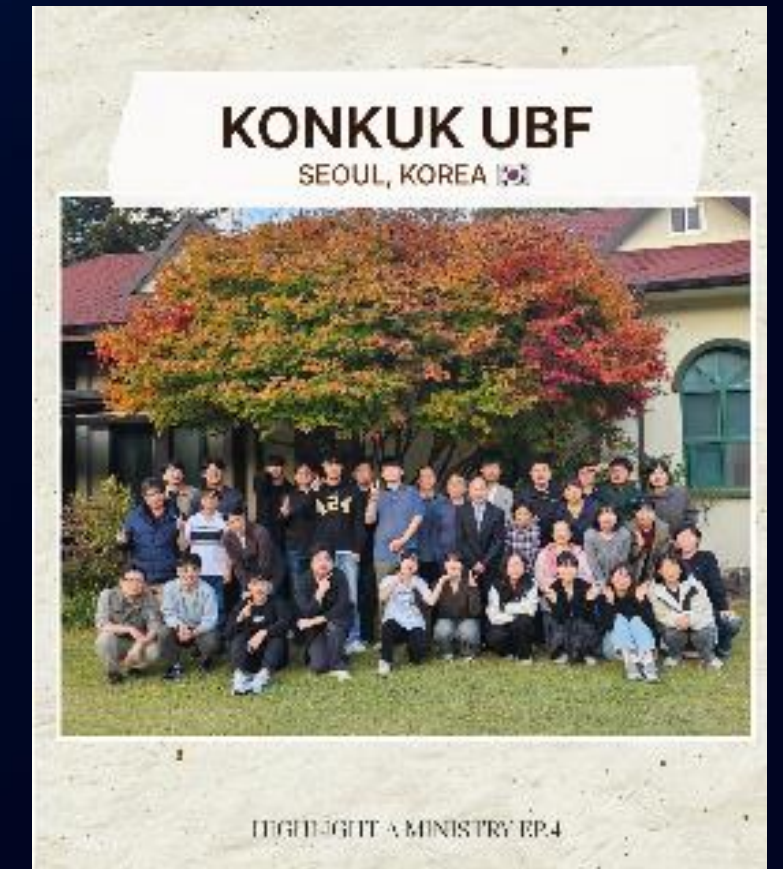

COLOGNE UBF

COLOGNE, GERMANY 🇩🇪



HIGHLIGHT A MINISTRY EP.5



When was Cologne UBF founded?

Cologne UBF was founded by Korean nurses in 1979. I was one of the days of the Cologne UBF that I experienced. I remember that to those described in Acts 2:44-47. I remember that someone invited me to dinner, I did Bible study with someone every week, went to church on Wednesday, and attended events every Wednesday. There was laughter, service, and the joy of God's Word.



one thing you're grateful for about the UBF?

I'm grateful for my Bible teacher Walter Nett, who gave me his all so that a lost sheep like me could find Jesus.



IZTACALA UBF

TLALNEPANTLA DE BAZ, MEXICO 🇲🇽



When was Iztacala UBF founded?

Sent to Mexico in 1997 as an expatriate employee of LG Electronics, missionary Isaac Park received God's calling through Ezekiel 37:10 in 2001. Moved by this vision, he resigned from his job and chose to remain in Mexico. In January 2002, together with another missionary, he founded Iztacala UBF.



How did you first start going to Iztacala UBF?

Missionary Servo came to preach at the university when I was a second-year medical student in 2009. Christ's love and grace led me to Iztacala UBF.

What makes Iztacala UBF unique?

I have been able to find a family in Christ. Despite our differences, we always support one another and pray for each other. I also love the pure teaching of the Word, the personal guidance, and the one-on-one Bible studies. The love and dedication of the members of the church are also very special.

What's one thing you're grateful for about Iztacala UBF?

It helped me come to know the Word of God during a difficult moment in my life. Through UBF, I was able to find my Savior and develop an identity in Christ. My pastor helped me discover my musical talent through violin lessons. I am grateful that I can now serve in the mini-orchestra and bring my 3-year-old daughter, Thelma, to church with me.



What passages/book of the Bible are you studying right now?

We are studying the Book of Acts, along with some special Christmas readings.

What are your prayer topics for Iztacala UBF in 2025 (or for the upcoming year)?

- Strengthening family-centered discipleship
- Deepening fellowship and pastoral care
- Continuing to raise leaders with humble and loving hearts

Thank you Iztacala UBF!

Interviewed:
Pastor Jorge David Rios & Missionary Isaac

Want your chapter to be featured?
DM us @ubfwhysyde/fellowship

2026 DIRECTION: EXPANSION



TIKTOK VISIBILITY



EXPANDING PRESENCE



SUPPORTING LOCAL CHAPTERS



AI TOOLS & TRAINING

▶ **TikTok Search Visibility**

UBF HQ channel activation; encourage chapter participation.

▶ **GEO — Generative Engine Optimization**

Strategy + UBF blog platform so AI engines (ChatGPT, Gemini, Perplexity) cite UBF positively.

▶ **Online Outreach Pilot**

6 chapters selected (IIT, Toledo, Madison, NJ, Dupage, +1) — expanding toward 10.

▶ **Campus Ministry Tools — keep building**

Ongoing development; broader chapter adoption.

▶ **AI Training for UBF Members**

Practical AI series for campus ministry application.

▶ **Inductive AI Bible Study**

Web + app currently in development.

▶ **NA Chapter Support**

Training, sharing, and ongoing support for North America chapters.

UBF Daily Bread – Voice Service Transition

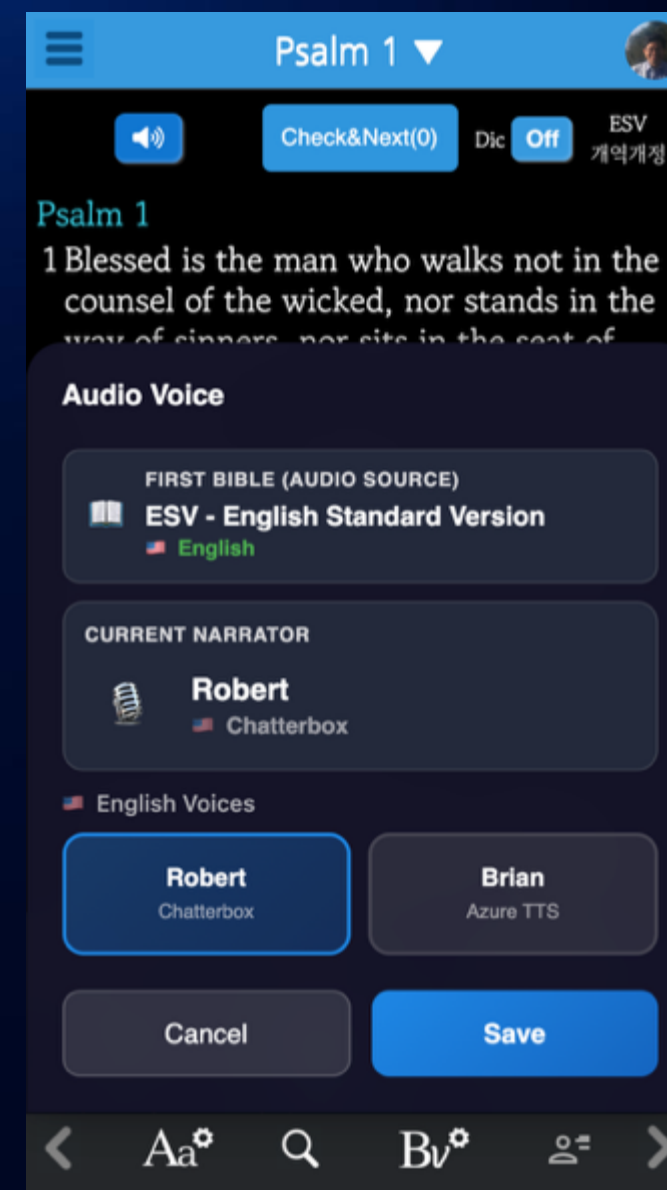
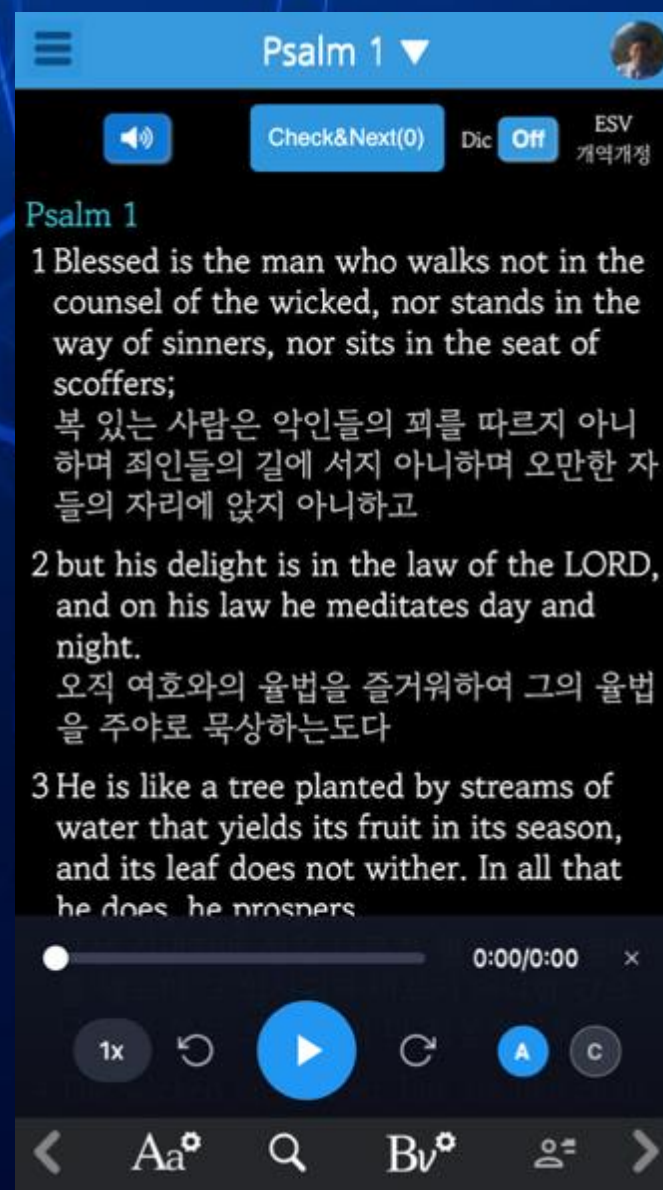
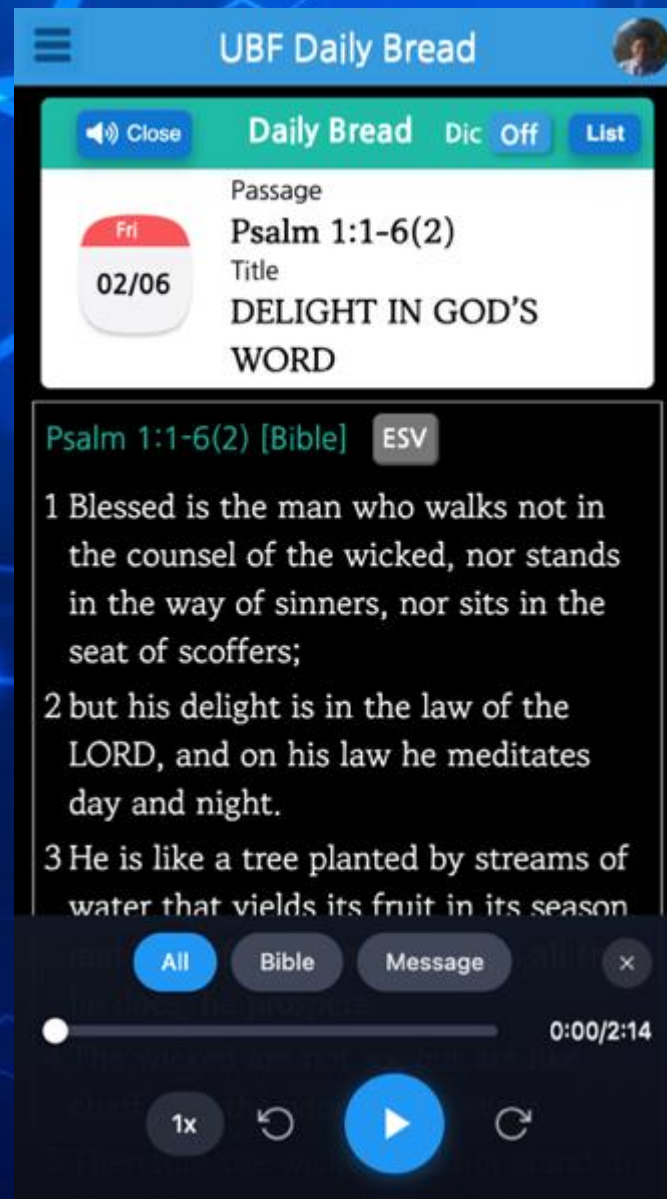

UBF Daily Bread Voice Service — AI TTS auto-generates ~5 minutes of natural Korean and English audio devotional daily; over a thousand users now listen during commutes, replacing what once required a full-time voice actor.

Image Bible Narration

The screenshot displays three panels of an image Bible narration interface for John 5:19. Each panel features a different artistic style for the scene: 'Real', 'Toon', and 'Art'. Below each image is a text box with the verse and a video player.

Panel 1 (Real): The Son Gives Life · vv.19-47. Real. 19 Jesus gave them this answer: "Very truly I tell you, the Son can do nothing by himself; he can do only what he sees his Father doing, because whatever the Father does the Son also does." For the Father loves the Son and...

Panel 2 (Toon): The Son Gives Life · vv.19-47. Toon. 19 Jesus gave them this answer: "Very truly I tell you, the Son can do nothing by himself; he can do only what he sees his Father doing, because whatever the Father does the Son also does." For the Father loves the Son and...

Panel 3 (Art): The Son Gives Life · vv.19-47. Art. 19 Jesus gave them this answer: "Very truly I tell you, the Son can do nothing by himself; he can do only what he sees his Father doing, because whatever the Father does the Son also does." For the Father loves the Son and...

Image Bible Narration — 3 to 8 detailed scene images for every one of 1,189 chapters across all 66 books (~6,000 images) via GPT-image 2.0; every image reviewed for theological accuracy before visual appeal.

Trilingual service (Korean, English, and Spanish)

Prayer [World Mission] Public

English (HQ) Pray for P. Ron Ward and Continental New Year's Conferences

Spanish (HQ) Oren por el P. Ron Ward y las Conferencias de Año Nuevo Continental

Korean (HQ) P. Ron Word와 대륙 신년 수양회를 위해 기도해 주세요.

본 번역은 인공지능(AI)에 의해 생성된 것이므로 일부 정확하지 않을 수 있습니다. [영어](#) [스페인어](#)

본 뉴스 번역 페이지는 이메일 배포용으로만 제공되는 자료입니다. 웹사이트 게시 또는 소셜미디어 공유는 삼가해주시기 바랍니다.

WM News & PTs 02/07/2026

(라틴 아메리카) 라틴 아메리카 지부장 및 리더 신년 수양회 2026 (작성자: Isaac Park)

2026년 1월 23일부터 25일까지, 라틴 아메리카 지부장 및 리더 신년 수양회가 칠레 산티아고에서 열렸으며, 약 70명의 리더들이 새로운 해를 위한 영적 지도와 비전을 위해 모였습니다. 이 수양회는 2025년 선교 여정을 반성하고 말씀 중심, 사랑 중심, 기도 중심의 사역으로 재조정하는 중요한 영적 전환점을 의미했습니다. 주요 메시지로 “경건함을 위해 너 자신을 훈련하라”는 디모데전서 4장으로부터의 내용으로 실질적인 순종을 강조하였고; “서로 사랑하라”는 요한복음 13장에서부터 예수의 사랑의 역학은 강조하였으며, “하산 기도하고 난사하지 마라”는 누가복음 18장으로부터 지속적인 기도

UBF NEWSLETTER

UNIVERSITY BIBLE FELLOWSHIP

This newsletter is also available in Korean and Spanish. [한국어](#) [Español](#)

WM News & PTs 02/07/2026

(Latin America) Latin America Chapter Directors & Leaders New Year Conference 2026 (by Isaac Park)

From January 23 to 25, 2026, the Latin America Chapter Directors and Leaders New Year Conference took place in Santiago, Chile, with around 70 leaders gathering for spiritual direction and vision for the

Esta traducción fue generada por inteligencia artificial (IA) y puede no ser completamente precisa. [Inglés](#) [Coreano](#)

Esta página de traducción de noticias se proporciona únicamente para su distribución por correo electrónico. Por favor, absténgase de publicarla en sitios web o compartirla en redes sociales.

WM News & PTs 02/07/2026

Conferencia de Año Nuevo 2026 para Directores y Líderes de Capítulos de América Latina (por Isaac Park)

Trilingual newsletter — AI auto-translates and summarizes the Korean original into English and Spanish; ministers only review, and Spanish-speaking mission fields in Latin America now receive HQ news regularly.

Prayer Map App

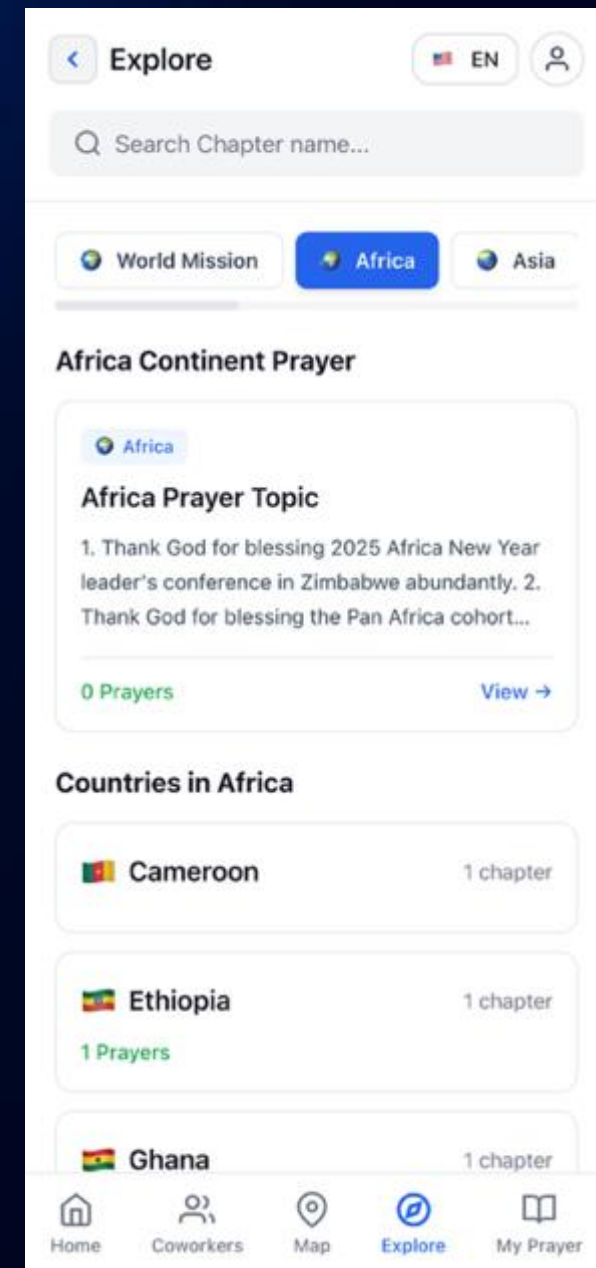
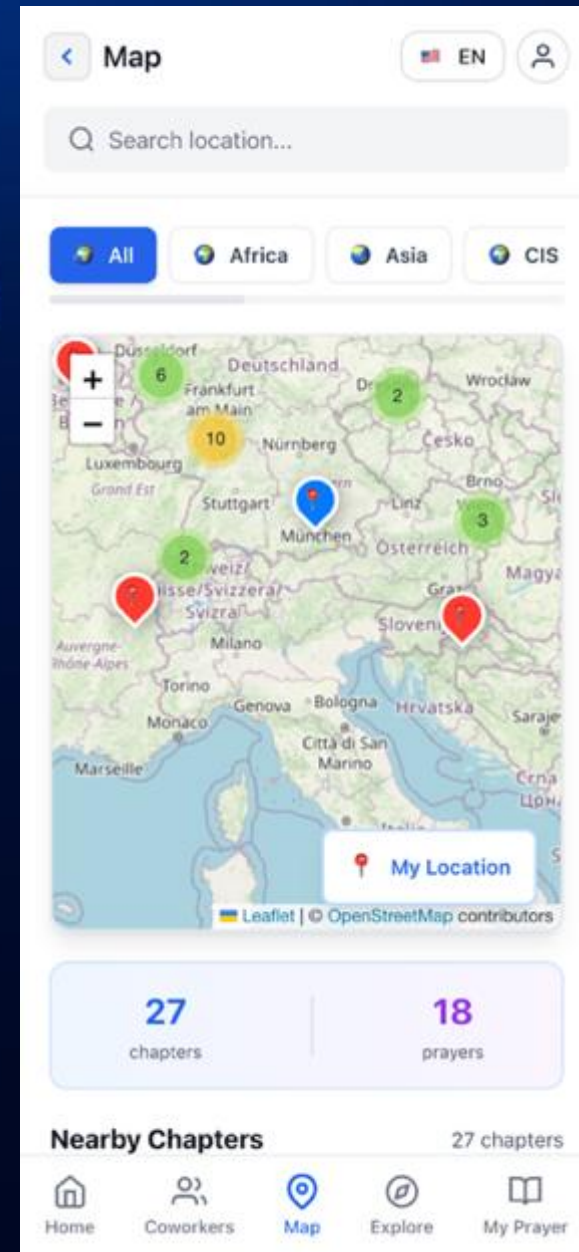
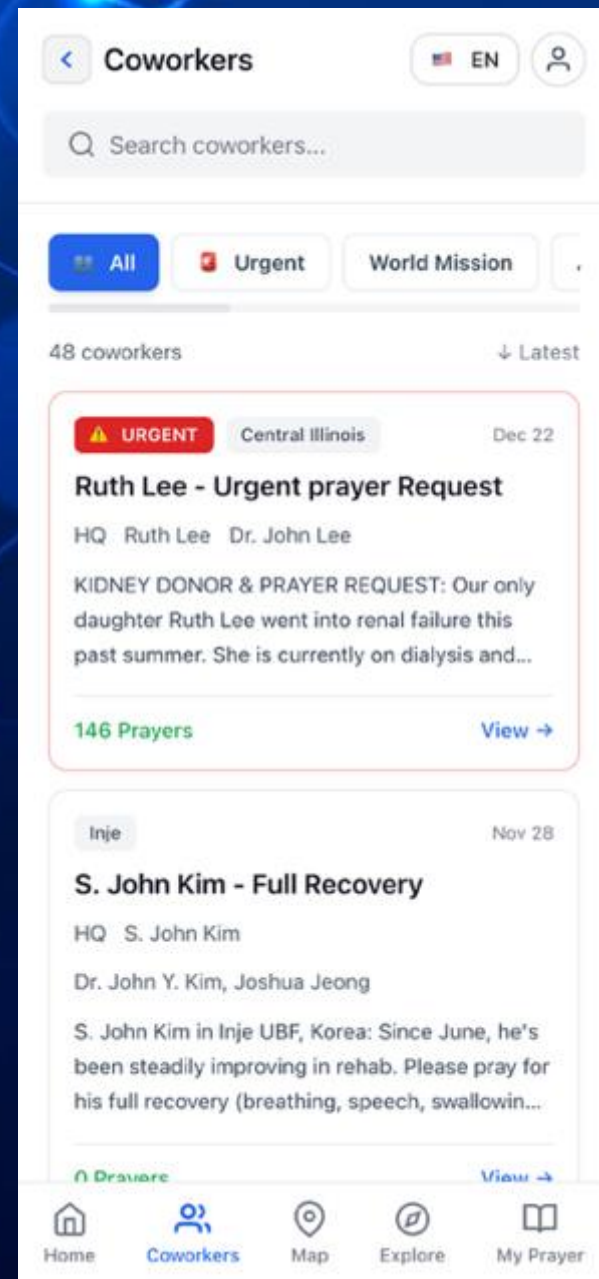
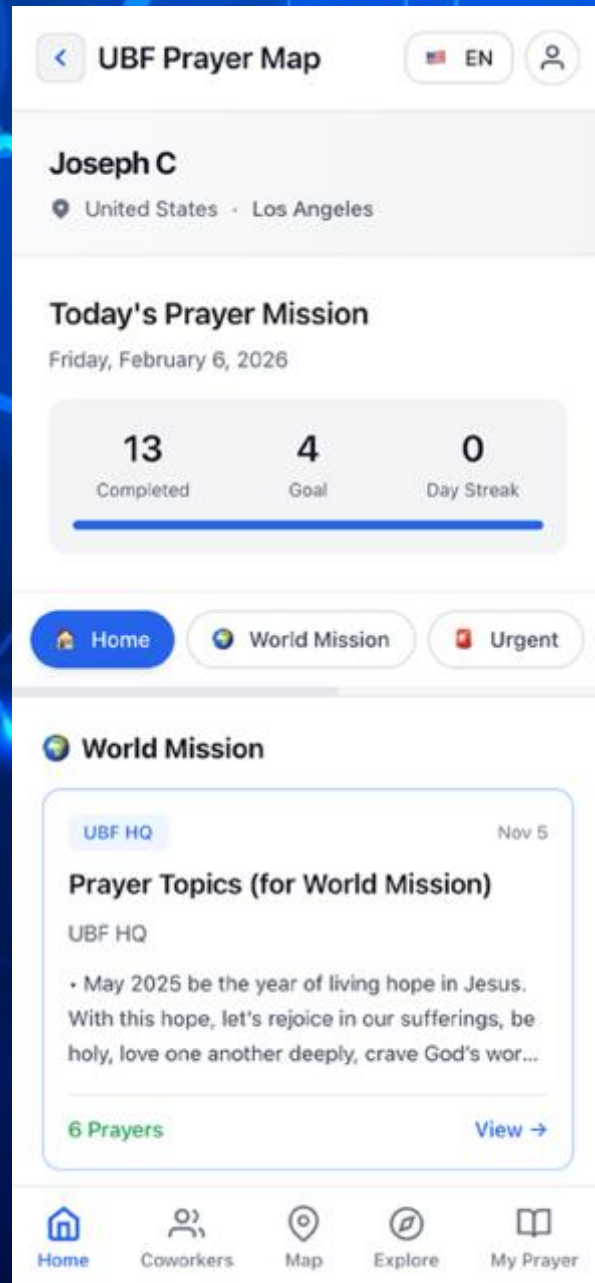

Bible Memorization App

The home screen features a dark theme with a blue geometric pattern in the background. At the top, it says "Hello!" and "Walk with the Word today" next to a purple profile icon with the letter 'J'. Below this are three stat cards: "3 Streak days" with a flame icon, "7 Level" with a star icon, and "61 Memorized" with an open book icon. A progress bar shows "Level 7" with "2300 XP" and "2500 XP to Level 8". A "Due for Review" section shows "20 verses" with a target icon and "Romans 5:8 and more...". At the bottom, there are "Collections" for "Navigators 60" (38/60) and "Love Chapter" (0/13), with two more partially visible. A bottom navigation bar includes Home, Library, Learn, and Profile.

The "Learning Mode" screen offers four practice methods: "Flashcard" (Flip cards to reveal and review verses), "Fill in Blank" (Type the missing words to complete verses), "Word Scramble" (Arrange scrambled words in correct order), and "Audio Mode" (Listen repeatedly to memorize by ear). Each method is represented by an icon and a right-pointing arrow. A bottom navigation bar includes Home, Library, Learn, and Profile.

The "Fill in Blank" screen shows the verse "Galatians 2:20" with seven blanks. The text is: "I have been crucified with Christ blank 1 I no longer blank 2 but Christ lives in me. The life I blank 3 live in blank 4 body, I live by faith in blank 5 Son of blank 6 who loved me and blank 7 himself for me." A "Check" button is at the bottom, and a "Show Answer" button is below it. A bottom navigation bar includes Home, Library, Learn, and Profile.

The "Audio Mode" screen displays the same verse as the "Fill in Blank" screen. It features a large blue play button with a white audio waveform icon. Below the play button is a "Stop Practice" button with three dots. At the bottom, there are "Driving Mode" and "Next →" buttons. A bottom navigation bar includes Home, Library, Learn, and Profile.

Chicago UBF Website Redevelopment

A modern church-style site rebuilt from the ground up using the latest AI-assisted development workflow.

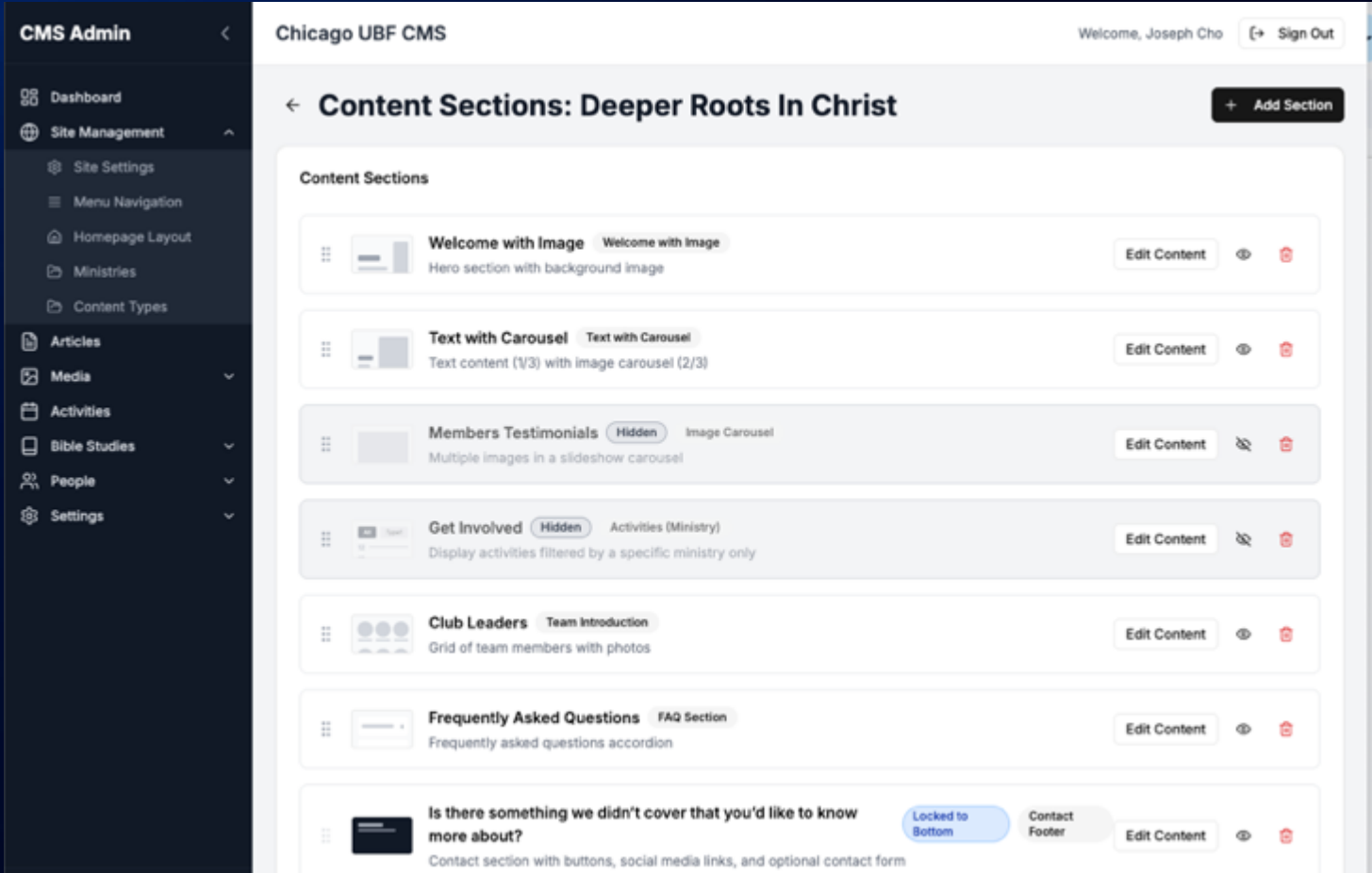
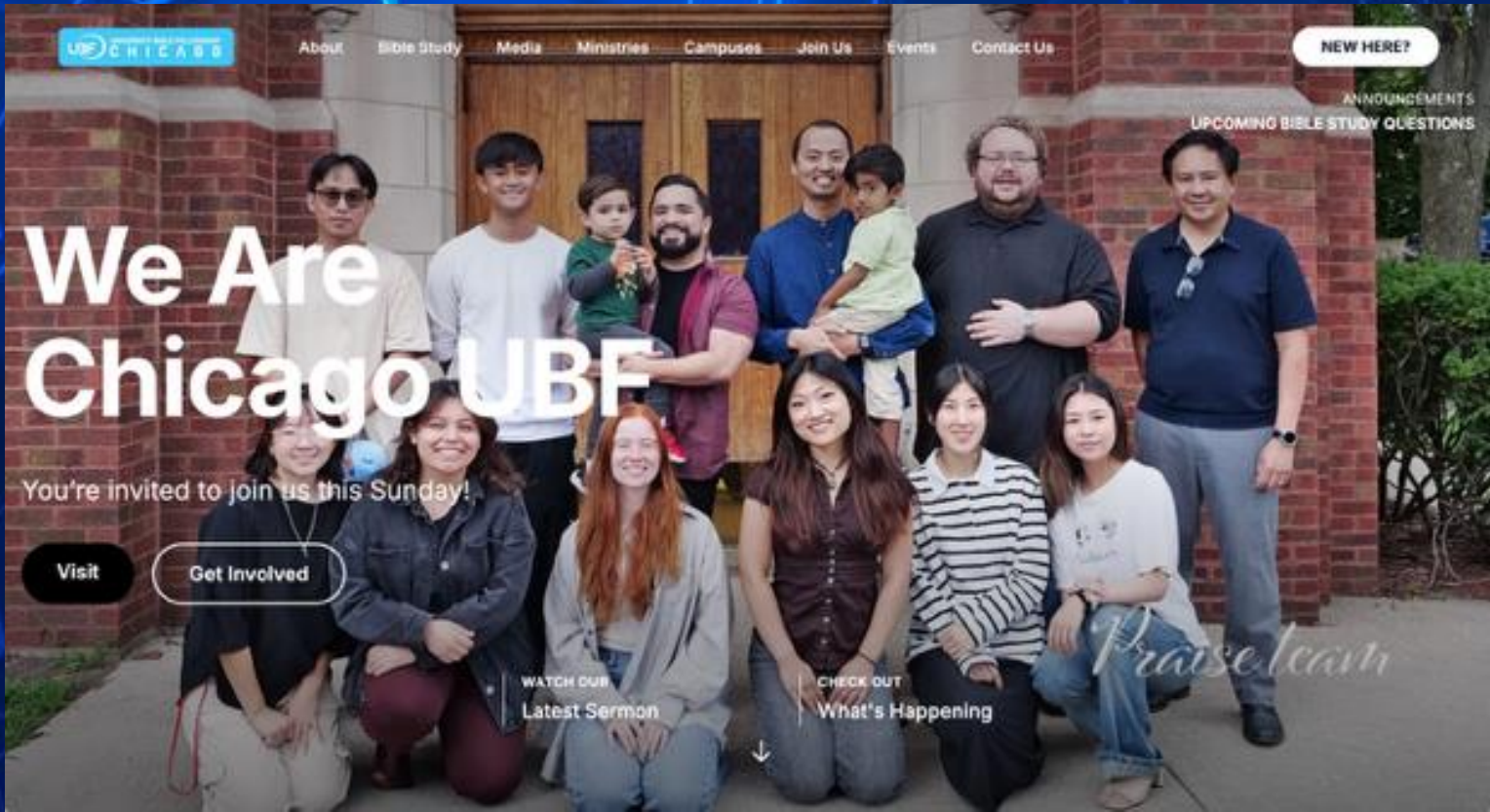

CMS

LA UBF Website Redevelopment

A modern church-style site rebuilt from the ground up using the latest AI-assisted development workflow.

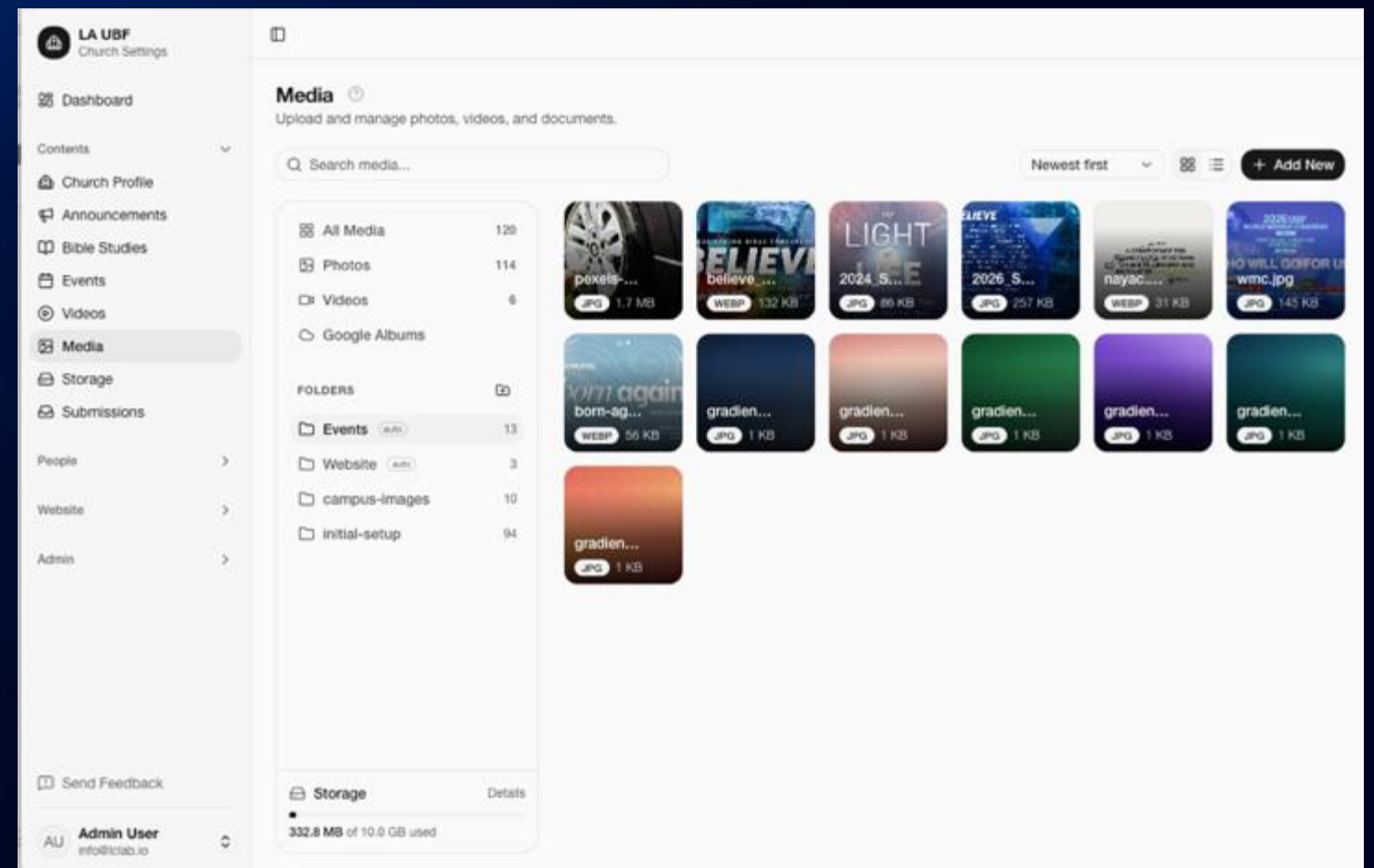

CMS

LC Lab — Digital Church Transformation

Wider Christian community

Project 8: a startup
founded by the presenter



UBF-validated

LC Lab

Korean
Churches
(KR)

Korean-American
Churches
(US-KR)

English-speaking
Churches
(EN)

Unifies UBF-validated
ministry solutions

Shares AI-era ministry
know-how outward

Korean → Korean-American
→ English-speaking churches

Campus Evangelism Support System

In Planning

Three tools serving one evangelism pipeline

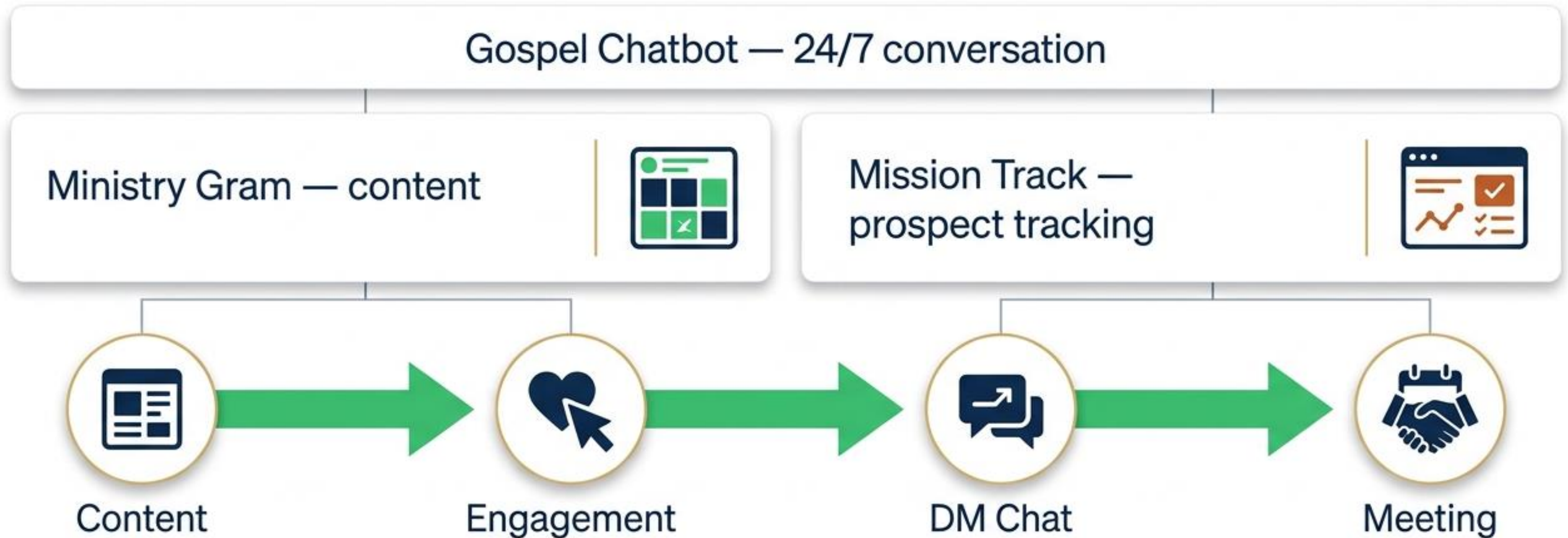

Flow: Content → DM → Meeting

Campus Ministry Gram (in development)

AI-powered Instagram content management for campus ministry



Solves the “what do I post today?” blank-page problem

Auto-recommends daily content from chapter info + weekly flow

Minister only reviews and approves

Planning time: **1 hour → 5 minutes**

An Instagram Content Management Platform for Campus Ministry

This Week's Schedule (Jan 15 - 21)

Day	Post Type	Time	Status
Mon	Scripture	9:00 AM	Scheduled
Tue	Rest		
Wed	GBS Promo	6:00 PM	In Progress
Thu	Rest		
Fri	Devotional	12:00 PM	Idea
Sat	Rest		
Sun	Worship Highlights	8:00 PM	In Progress

Posting Settings

Weekly Goal: 3 posts/week
Reminder: 1 hour before

Recommended Content Ideas (Get AI Suggestions)

- Verse of the Day Card** (Scripture) - John 15:5 - The Vine and Branches
- GBS Recruitment Reminder** (Promo) - This Wednesday 7 PM, Student Center
- Worship Reels** (Media) - Last Sunday worship team practice clip
- Campus Walk Vlog** (Lifestyle) - Short devotional on a fall campus walk

Daily Content Guide

- Monday: Scripture card to start the week
- Wednesday: GBS/Small group promo
- Friday: Weekend worship invite
- Sunday: Worship highlights & testimonies

Pro Tip: Campus students are most active during lunch (12-1 PM) and evenings (7-9 PM)

Media Library (Upload)

- sunday_group_photo.jpg (Jan 14, 2024)
- worship_practice_clip.mp4 (Jan 13, 2024)
- gbs_meeting_photo.jpg (Jan 10, 2024)
- campus_scenery.jpg (Jan 9, 2024)

AI Content Generator (Automatically create images and videos)

- Scripture Cards**: Auto-generate beautiful verse images
- GBS Posters**: Create small group recruitment flyers
- Reels Video**: Auto slideshow from your photos
- Story Templates**: Create interactive story content

Select photos from your library and AI will automatically generate post-ready content.

Scheduled Post Queue (+ New Schedule)

- John 15:5 Scripture Card**: Today 9:00 AM (Feed) - Ready
- Wednesday GBS Meeting Invite**: Jan 17, 6:00 PM (Feed + Story) - Draft
- Sunday Worship Highlights**: Jan 21, 3:00 PM (Reels) - Processing

Instagram Connected (@campus_ministry Connected) - Account Settings

Automation Settings

- Auto-add hashtags:
- Optimize posting time:
- Auto-share to Story:



Verse of the Day Card

Scripture



Content Preview

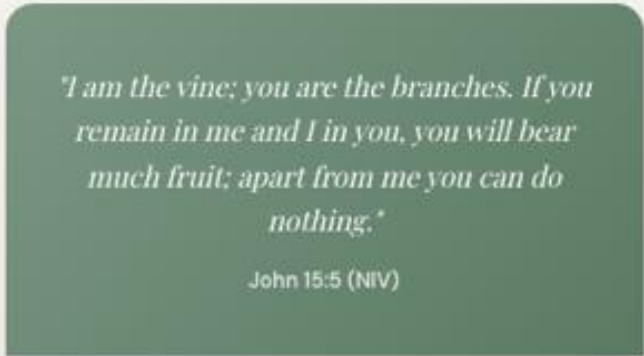

Apart from Him, we can do nothing. But connected to the Vine? We bear fruit that lasts...

Suggested Caption

Copy

Apart from Him, we can do nothing. But connected to the Vine? We bear fruit that lasts.

This week, let's stay rooted. Stay connected. Stay faithful.

What's one way you're staying connected to Jesus today?

Suggested Hashtags

Copy

- #campusministry
- #biblestudy
- #faithoncampus
- #johnfifteen
- #abideinchrist
- #collegelife
- #spiritualgrowth
- #verseoftheday

Suggested Color Themes

- Soft green & cream
- Navy & gold
- Warm terracotta



Best Time
Monday 9:00 AM



Format
Square (1:1)



Estimated Reach
150-300 students

Customize Idea

Generate Content

Add to Schedule



GBS Recruitment Reminder

Profile



Content Preview



Best Time

Wednesday 12:00 PM

Format

Portrait (4:5)

Suggested Caption

Copy

Looking for community? Searching for purpose?

Join us this Wednesday for Group Bible Study! We're diving into the Gospel of Mark and discovering what it really means to follow Jesus.

Wed, Jan 17 @ 7 PM
Student Center Room 204
Free pizza included

Bring a friend, no experience needed. Just come as you are.

Suggested Hashtags

Copy All

- #gbs
- #biblestudy
- #campusministry
- #communitycampus
- #collegelife
- #studywithus
- #wednesdaylights

Suggested Color Themes

- Bold orange & white
- Deep blue & yellow



Worship Reels

Media



Content Preview



Best Time

Saturday 6:00 PM

Format

Reels (9:16)



Estimated Reach
300-600 students

Suggested Caption

Copy

There's something powerful about lifting our voices together.

Catch a glimpse of our worship team preparing their hearts for Sunday. We can't wait to worship with you this weekend!

Sunday @ 10 AM
Main Auditorium

Suggested Hashtags

Copy All

- #worshipmusic
- #sundayservice
- #campusworship
- #praiseteam
- #worshipreels
- #collegeworship
- #faithandmusic

Suggested Color Themes

- Warm ambient lighting
- Natural tones
- High contrast 86W

Customize Idea

Generate Content

Add to Schedule



Campus Walk Vlog

Lifestyle



Content Preview



Best Time

Friday 12:00 PM

Format

Reels (9:16)



Estimated Reach
250-500 students

Suggested Caption

Copy

Sometimes the best sermons happen on a walk across campus.

Take a breath, look around. God's presence is everywhere—even in the chaos of midterms.

"Be still, and know that I am God" - Psalm 46:10

Where do you find peace on campus?

Suggested Hashtags

Copy All

- #campuslife
- #devotional
- #peaceoncampus
- #collegelife
- #faithjourney
- #bestill
- #campuswalk
- #knowinggod

Suggested Color Themes

- Autumn warm tones
- Golden hour
- Natural palette

Customize Idea

Generate Content

Add to Schedule

Mission Track (in design)

Sisters Username	Contacted	Reply in Progress	Confirmed Bible Study	Confirmed Appointment	Bible Teacher	Brothers Username	Contacted	Reply in Progress	Confirmed Bible Study	Confirmed Appointment
@example	✓	✓	yes	Friday @ 10am	Megan	@example	✓	✓	yes	Friday @ 10am
dmz x	✓	✓				eduardo	✓	✓		
rafa lefocin	✓	✓				samuel_rodriguez	✓	✓		
montseve2	✓	✓				bruno_u	✓	✓		
alisonjenahk	✓	✓				nicolas	✓	✓		
lga	✓	✓				lake.r.115	✓	✓		
ibotamara	✓	✓				henry_1942	✓	✓		
hales_l_may	✓	Not interested				andycypress	✓	✓		
hard	✓	Not interested				drakeshire_dr	✓	✓		
nutysolana	✓	Not interested				agonmign97	✓	✓		
vivahessa	✓	Not interested				dmariopet	✓	✓		
woke_laure	✓	Not interested				spook.avi	✓	✓		
21jessica_	✓	Not interested				lun.mp4	✓	✓		
timberlyanv	✓	Not interested				leor_jenkins	✓	✓		
alo	✓	Not interested				dannycramer	✓	✓		
janther olvive	✓	Not interested				josuej99	✓	✓		
z	✓	Not interested				brandonz_56	✓	✓		
uppest3	✓	Not interested				michael.o.a.m	✓	✓		
behind_the_pi	✓	Not interested								
ate_tate	✓	Not interested								
blissy marie	✓	Not interested								
casodetery	✓	Not interested								

Mission Track

MAIN MENU

- Dashboard
- Prospects **247**
- Messages **12**
- Bible Studies

MANAGEMENT

- Analytics
- Settings

SJ Sarah Johnson
Outreach Lead

Dashboard

Spreading the Gospel, one connection at a time 🙌

Export Add Prospect

+12%

247
Total Prospects

+8%

168
DMs Sent

+23%

58
Interested

+15%

24
Enrolled

Recent Prospects

NAME	SOURCE	STATUS	ADDED
EM Emma Mitchell @emma_daily	Instagram	Interested	Today
JW James Wilson @james_wilson	Instagram	Contacted	Yesterday
OG Olivia Garcia @olivia.g	Instagram	Enrolled	Jan 18
MC Michael Chen @michael_chen99	Instagram	New	Jan 17
SL Sophia Lee @sophia.lee	Instagram	Interested	Jan 16

Recent Activity

- Olivia Garcia enrolled in Bible study 30 minutes ago
- Emma Mitchell replied to your DM 2 hours ago
- Sent invitation DM to James Wilson Yesterday
- Sophia Lee completed Lesson 1 Yesterday

Conversion Funnel

Total Prospects	247
DMs Sent	168
Interested	58
Enrolled	24

Mission Track

Track your outreach performance and conversions

Last 30 days | Export Report

247
Total Prospects

68%
Response Rate

35%
Interest Rate

9.7%
Enrollment Rate

Outreach Activity

Prospect Status

247 Total

- Contacted: 89
- Interested: 58
- New: 42
- Other: 58

Conversion Funnel

Total Prospects	247	100%
DM Sent	164	68%
Interested	58	35%
Enrolled	24	9.7%

Top Sources

Instagram	80% of prospects	210
Facebook	6% of prospects	25
Referral	1% of prospects	12

Weekly Activity by Day

Mission Track

MAIN MENU

- Dashboard
- Prospects **247**
- Messages **12**
- Bible Studies

MANAGEMENT

- Analytics
- Settings

Mission Track

MAIN MENU

- Dashboard
- Prospects **247**
- Messages **12**
- Bible Studies

MANAGEMENT

- Analytics
- Settings

SJ Sarah Johnson
Outreach Lead

Prospects

Manage and track your evangelism contacts

Search by name, handle, or notes...

Source | Date Range | More Filters

All **247** | New **42** | Contacted **89** | Interested **58** | Enrolled **24** | Inactive **34**

Select All | Send DM | Add Tag | Delete

NAME	SOURCE	STATUS	ADDED	NOTES	ACTIONS
EM Emma Mitchell (@emma_daly)	Instagram	Interested	Today	Asked about study tim...	🗄️ ⋮
JW James Wilson (@james_wilson)	Instagram	Contacted	Yesterday	Sent intro message	🗄️ ⋮
OG Olivia Garcia (@olivia.g)	Instagram	Enrolled	Jan 18	Starting lesson 1	🗄️ ⋮
MC Michael Chen (@michael_chen99)	Instagram	New	Jan 17	-	🗄️ ⋮
SL Sophia Lee (@sophia.lee)	Instagram	Interested	Jan 16	Prefers weekends	🗄️ ⋮
DK David Kim (@davidk.official)	Instagram	Inactive	Jan 10	No response after 3 DMs	🗄️ ⋮

Bible Studies

Manage courses and track student progress

Add Student | Create Course

Active Students

24

↑ 3 this week

Courses Available

3

Lessons Completed

156

↑ 12 this week

Avg. Completion

68%

↑ 5% from last month

Available Courses

Manage Courses

Foundations of Faith

An introductory course covering the basics of Christianity and core beliefs.

8 Lessons

Prayer & Meditation

Learn different forms of prayer and how to develop a deeper spiritual life.

6 Lessons

Living with Purpose

Discover God's purpose for your life and how to live it out daily.

10 Lessons

Student Progress

All Students | Active | Completed | Inactive

STUDENT	PROGRESS	CURRENT LESSON	LAST ACTIVITY	ACTIONS
OG Olivia Garcia Foundations of Faith	<div style="width: 87%;"></div> 87%	Lesson 7/8	Today, 2:30 PM	⋮
EM Emma Mitchell Foundations of Faith	<div style="width: 62%;"></div> 62%	Lesson 5/8	Yesterday	⋮
SL Sophia Lee Foundations of Faith	<div style="width: 37%;"></div> 37%	Lesson 3/8	2 days ago	⋮
JW James Wilson Prayer & Meditation	<div style="width: 16%;"></div> 16%	Lesson 1/6	Just started	⋮

Gospel Chatbot — Reaching Closed Regions

24/7 conversational AI for souls in closed regions

Targets Muslim-majority, post-Communist, closed nations

Theologically safe answers to spiritual questions

Natural handoff to a human minister at the decisive stage

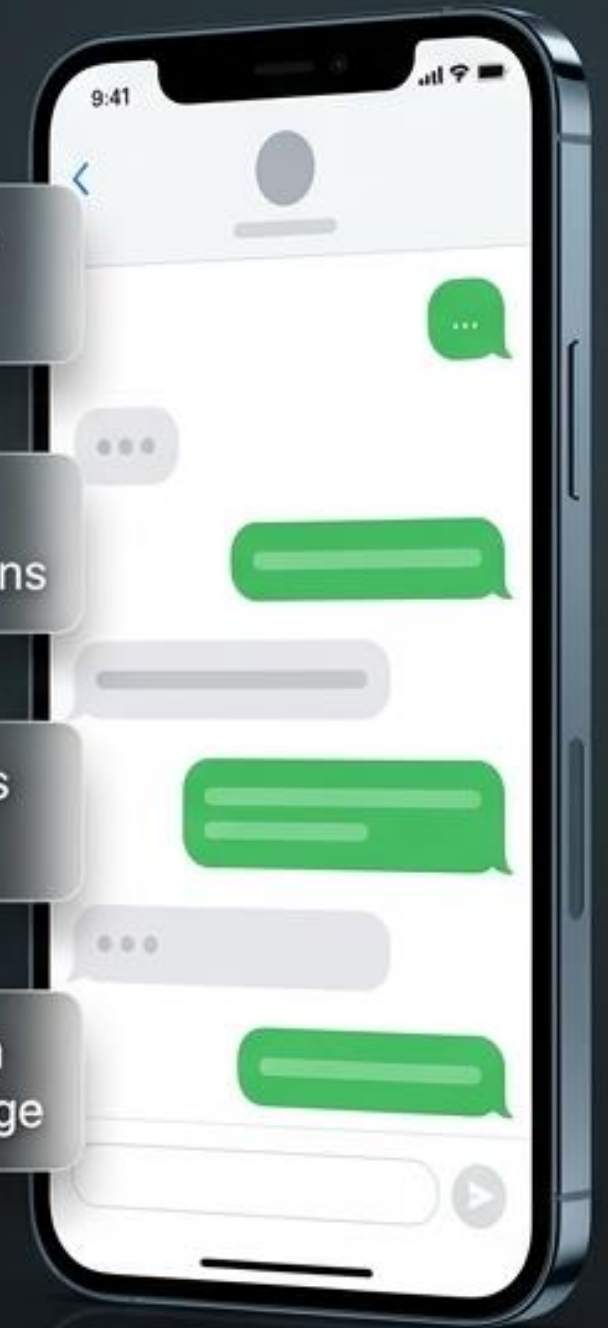

Where a missionary cannot reach, souls find us first

UBF AI Ministry Ecosystem

A holistic strategy across Outreach · Connect · Nurture

Every tool mapped to a ministry stage

	Outreach	Connect	Nurture
Currently Available	Web Platforms (Info Accessibility)	Newsletter Image Bible (Visual Word Sharing)	Prayer Map (Intercession Network) Memorization (Scripture in Heart)
In Planning/Dev	Ministry Gram (Social Media Ministry)	Gospel Chatbot (24/7 Response)	Mission Track (Short-term Mission Mgmt)

Your Resource Library

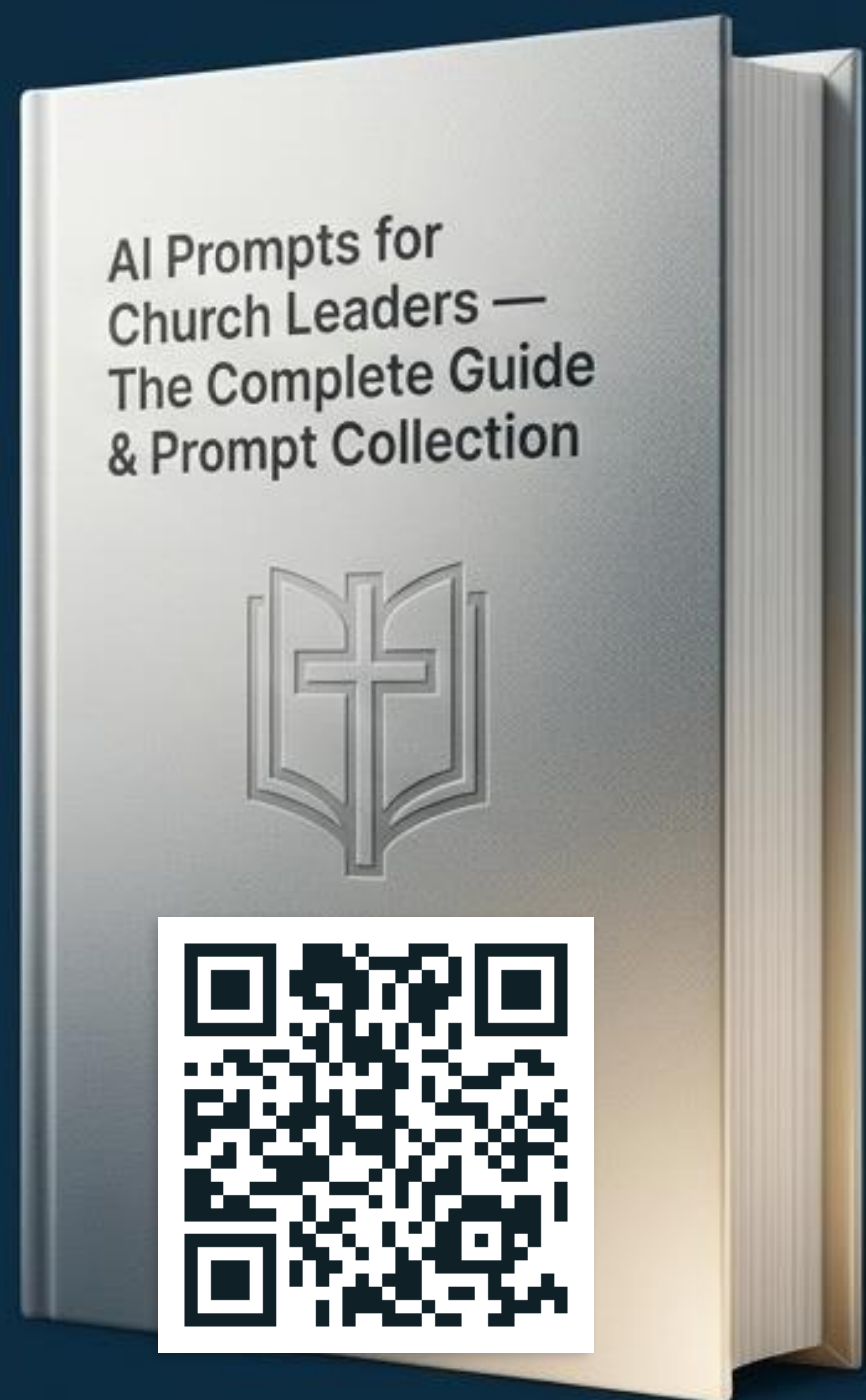

The Complete Guide & Prompt Collection

- "AI Prompts for Church Leaders" — the complete guide
- Compiled from 20+ leading sources
- 137+ ready-to-use prompts
- Categories: Sermon Prep, Bible Study, Pastoral Care, Administration

Available at ubf.org/online

Table of Contents — The Prompt Guide

PART I: THE ART OF PROMPTING FOR MINISTRY

Ch 1 Why Prompt Engineering Matters

- 1.1 AI Is an Assistant, Not a Preacher
- 1.2 What AI Can and Cannot Do in Ministry
- 1.3 The Right Mental Model: AI as Research Assistant
- 1.4 Why Prompt Engineering Still Matters

Ch 2 The 5 Core Principles

Role Assignment, Context Setting, Specific Requests, Constraints & Theological Safeguards, Output Format Specification

Ch 3 Prompt Quality Checklist

Ch 4 Common Mistakes & How to Fix Them

Ch 5 The Iterative Improvement Strategy

Ch 6 Master Prompt Templates

- Part I — The Art of Prompting for Ministry (Ch 1-6: Quality checklist, fixes, iteration, master templates)
- Three prompt types for UBF ministry and Bible study

Make IT and AI a Spiritual Weapon

Make IT and AI a powerful spiritual weapon for UBF's global campus mission.



[Tool]
IT & AI Technology



[Weapon]
Powerful Spiritual Weapons



[Mission]
World Campus Mission

We walked all four parts together in 90 minutes

Used with discernment, the tool gives back time and saves souls

The tool is not a threat

Our calling is renewed: **discern, shepherd, guide**

Download All Materials

Slide PDF, speaker notes,
references, tool links



ubf.org/online/ai-materials

Joseph Cho

✉ joseph.whcho@gmail.com

💬 KakaoTalk: danylight

Let us pioneer AI-era ministry together. Thank you.

Looking Ahead — Plans & Invitation

1.

**Online hands-on
training classes**

2.

**Digital Church
Transformation Platform —
A-to-Z support for chapters**

**Reach out
if you're
interested**

Joseph Cho —
joseph.whcho@gmail.com
• KakaoTalk: danylight

Thank You — Q&A

Thank you for being with me through this session

Now opening for Q&A

Let us pioneer AI-era ministry together

Download everything at ubf.org/online/ai-materials

